









	Seite / page 2 - 5	Sicherheitshinweise / Safety information marking / Sikkerhedshenvisninger
	Seite / page 6	
	Seite / page 7 - 13	 <p>Ø 4 x 16</p>   <p>PZ2</p> 
	Seite / page 14 - 19	 <p>6 10</p> <p>SL1</p>  <p>PZ2</p>  
	Seite / page 20 - 21	Demontage / disassembly

Kennzeichnung von Sicherheitshinweisen

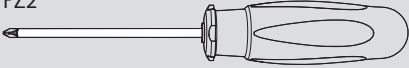
Sicherheitshinweise in dieser Anleitung weisen auf Gefahren hin, die durch bestimmte Handlungen oder das Unterlassen von Handlungen entstehen können. Sie benennen das Ausmaß der Gefährdung bei Nichtbeachtung der dort genannten Sicherheitsmaßnahmen.

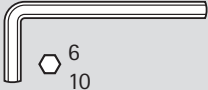
Sicherheitshinweise sind in der Betriebsanleitung wie folgt aufgebaut:

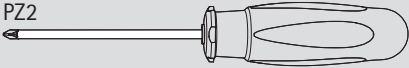

WARNUNG!

Dieser Gefahrhinweis weist auf eine **möglicherweise** gefährliche Situation hin, die zum **Tod** oder zu **schweren Verletzungen** führen **kann**, wenn die Sicherheitsmaßnahmen nicht befolgt werden



VORSICHT!

Dieser Gefahrhinweis weist auf eine **möglicherweise** gefährliche Situation hin, die zu **geringfügigen** oder **leichten Verletzungen** führen **kann**, wenn die Sicherheitsmaßnahmen nicht befolgt werden.



HINWEIS!

Dieser Hinweis weist auf **mögliche Sach- und Umweltschäden** hin, die entstehen können, wenn die Sicherheitsmaßnahmen nicht befolgt werden.



HINWEIS!

Alle Montagearbeiten dürfen ausschließlich von Fachpersonal für Möbel durchgeführt werden.



HINWEIS!

Alle Montagearbeiten mit mindestens 2 Personen durchführen.

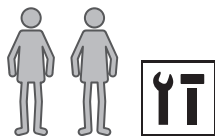

WARNUNG!

Verletzungsfahr und Sachschäden durch Kippen von ungesicherten Möbelstücken!

Beim Öffnen von ungesicherten Möbelstücken können Möbelstücke umkippen und schwere Verletzungen und erhebliche Sachschäden verursachen.

- Möbelstücke bei der Montage mit geeigneten Befestigungsmitteln an Wand oder Boden gegen Umkippen sichern.
- Anleitung der Möbelstücke des Möbelherstellers beachten.

Safety information marking

Safety information in this instruction manual draws attention to dangers that can arise from certain actions or the failure to take specific action. They indicate the extent of any hazard arising from the failure to observe the safety measures specified therein.

The safety information in these operating instructions is structured as follows:



WARNING!

This danger note draws attention to a potentially dangerous situation that may lead to death or serious injuries if the safety measures are not followed.



CAUTION!

This danger note draws attention to a potentially dangerous situation that may lead to minor or slight injuries if the safety measures are not followed



NOTE!

This information draws attention to potential damage to property and the environment that may occur if the safety measures are not followed.



NOTE!

All installation work must only be carried out by qualified furniture fitters.



NOTE!

Carry out all installation work with at least 2 people.

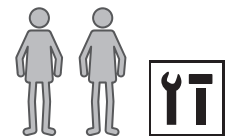

WARNING!

Risk of injury and damage to property from unsecured furniture tipping over!

On opening unsecured furniture, they can tip over and cause serious injuries and considerable damage to property.

- When fitting furniture, secure them to the wall or floor with suitable fasteners to prevent them from tipping over.
- Follow the instructions of the furniture manufacturer.

**VORSICHT!**

Verletzungsgefahr durch nicht fachgerecht ausgeführte Möbelstücke!

An beweglichen Möbelteilen können Quetsch- und Scherstellen sowie scharfe Kanten auftreten (z.B. bei hervorstehenden Ablageböden) und Verletzungen verursachen.

An gegenüberliegenden oder über Eck angeordneten Möbelstücken und anderen Gegenständen können Quetschstellen entstehen.

- Möbelstücke nach Stand der Technik bauen und montieren und ausschließlich entsprechende Möbelteile verwenden.
- Sicherstellen, dass Abstände an bewegten Bauteilen kleiner 8 mm oder größer 25 mm sind.
- Sicherstellen, dass bei der Planung und Montage ein Mindestabstand von 500 mm zu gegenüberliegenden und über Eck angeordneten Möbelstücken eingehalten wird.

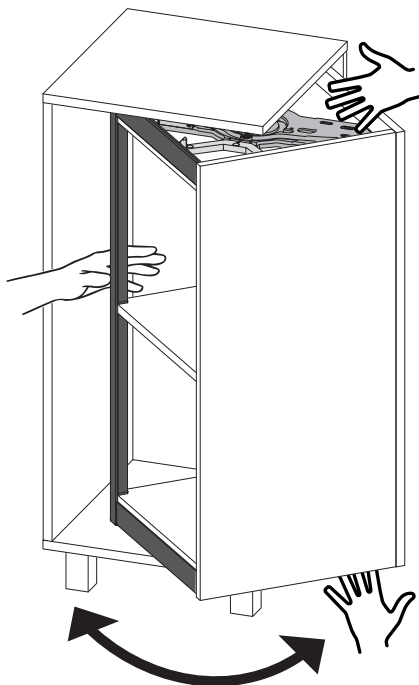
**CAUTION!**

Risk of injury from improperly assembled and fitted furniture!

Moving furniture parts can produce crushing and shearing points as well as sharp edges (e.g. for overlapping shelves), creating a source of injury.

Crushing points can result from opposite and cross corner furniture as well as from other objects.

- Construct and install furniture in line with the state of the art and only use appropriate furniture parts.
- Make sure that spacings at moving parts are less than 8 mm or greater than 25 mm.
- When planning and fitting cabinetry, be sure to allow a minimum distance of 500 mm to furniture positioned opposite or set across a corner.

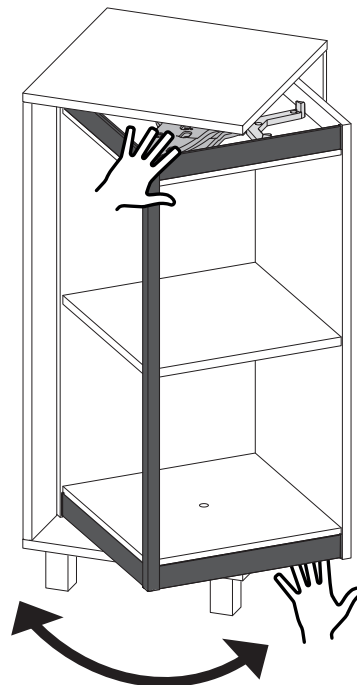

Markering af sikkerhedshenvisninger

Sikkerhedshenvisninger i denne vejledning henviser til farer, som kan opstå som følge af bestemte handlinger eller unkladelse af handlinger. De angiver farens omfang ved tilsidesættelse af de angivne sikkerhedsforholdsregler.

Sikkerhedshenvisningerne er opbygget på følgende måde i driftsvejledningen:



ADVARSEL!

Denne farehenvisning henviser til en **potentielt** farlig situation, som **kan** medføre **død** eller **alvorlig tilskadekomst**, hvis sikkerhedsforholdsreglerne ikke følges.



FORSIGTIG!

Denne farehenvisning henviser til en **potentielt** farlig situation, som **kan** medføre **ringe** eller **let tilskadekomst**, hvis sikkerhedsforholdsreglerne ikke følges.



BEMÆRK!

Denne henvisning henviser til **potentielle materielle skader og skader på miljøet**, som kan opstå, hvis sikkerhedsforholdsreglerne ikke følges.



BEMÆRK!

Alle montagearbejder må udelukkende udføres af faguddannet møbelpersonale.



BEMÆRK!

Alle montagearbejder skal udføres af mindst 2 personer.

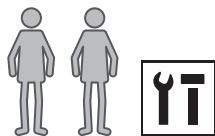

ADVARSEL!

Fare for tilskadekomst og materielle skader, hvis usikrede møbler vælter!

Når usikrede møbler åbnes, kan de vælte og forårsage alvorlig tilskadekomst og betydelige materielle skader.

- Ved montagen skal det sikres, at møbler ikke kan vælte ved fastgørelse til væg eller gulv med egnede midler.
- Følg møbelproducentens vejledning for møblerne.



PAS PÅ!

Der er fare for tilskadekomst ved ukorrekt udførte møbler!

Alle bevægelige møbler kan have steder med fare for klemning, klipning eller med skarpe kanter (f.eks. ved udragende hylder), som kan forårsage tilskadekomst.

Der kan opstå steder med fare for klemning, hvis møbler placeres overfor hinanden eller i hjørner eller i forbindelse med andre genstande.

- Møbler skal konstrueres og monteres i henhold til de tekniske regler og udelukkende under anvendelse af korrekte møbeldele.
- Sørg for, at afstanden mellem bevægelige komponenter er mindre end 8 mm eller større end 25 mm.
- Sørg for ved planlægningen og montagen, at der er en mindsteafstand på 500 mm til møbler på modsat side og til møbler, som er anbragt i hjørner.

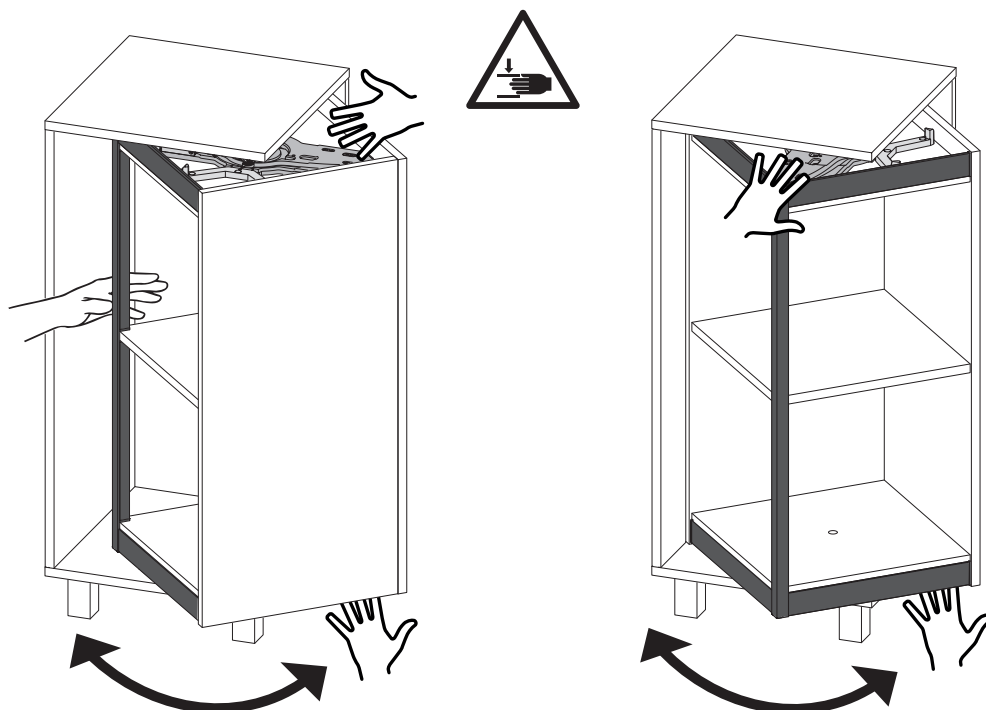

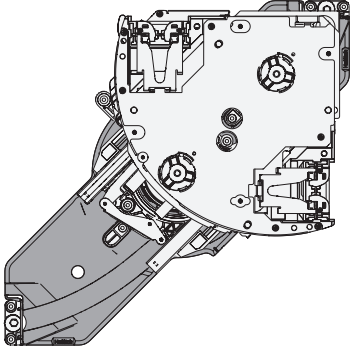
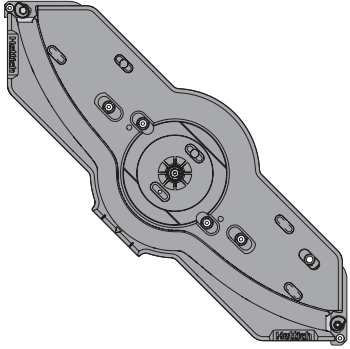
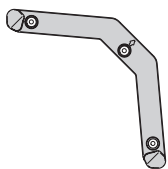
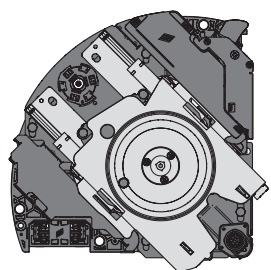

Pos.	1	2	3	4
	Seite / page 7 - 8	Seite / page 9	Seite / page 7 + 9	Seite / page 11
				

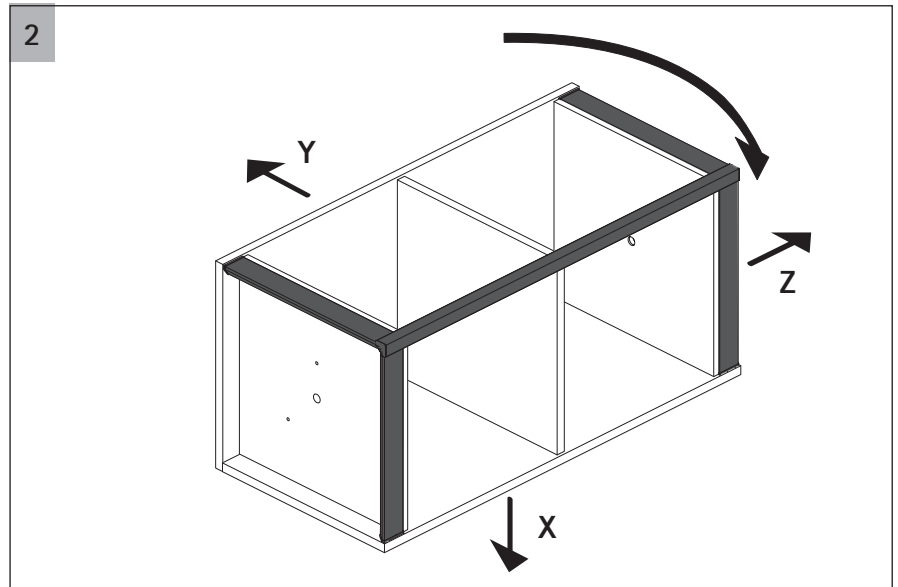
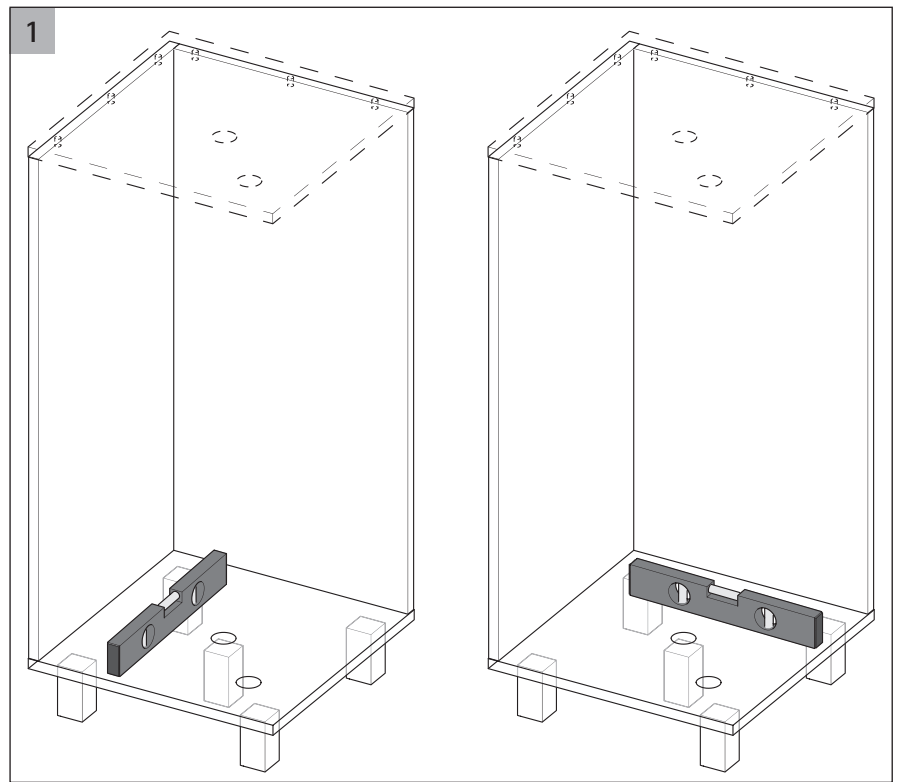
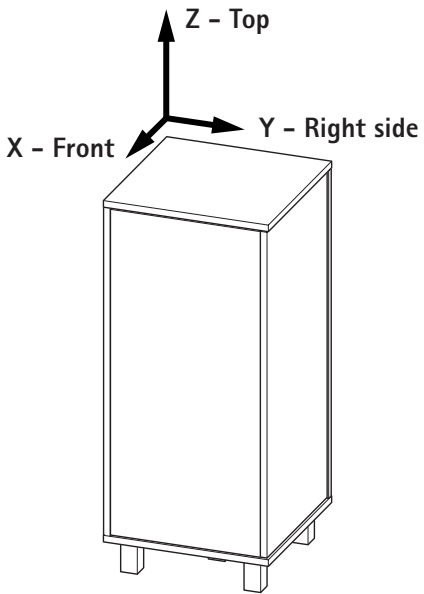

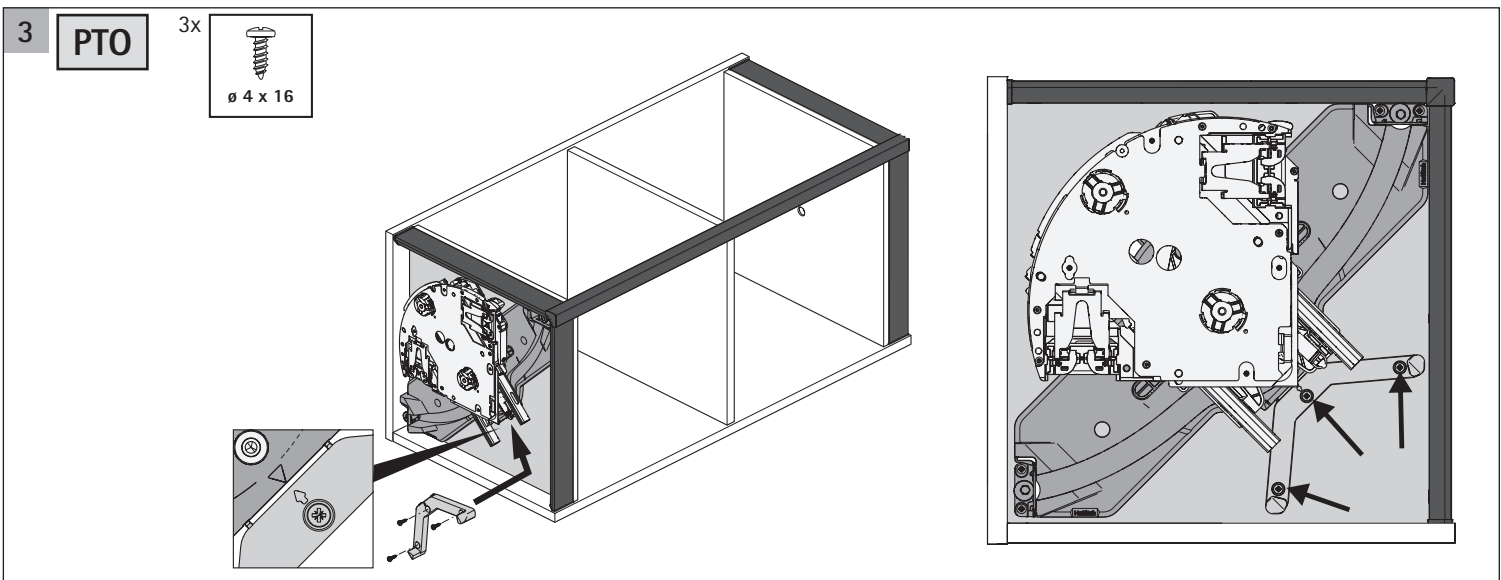
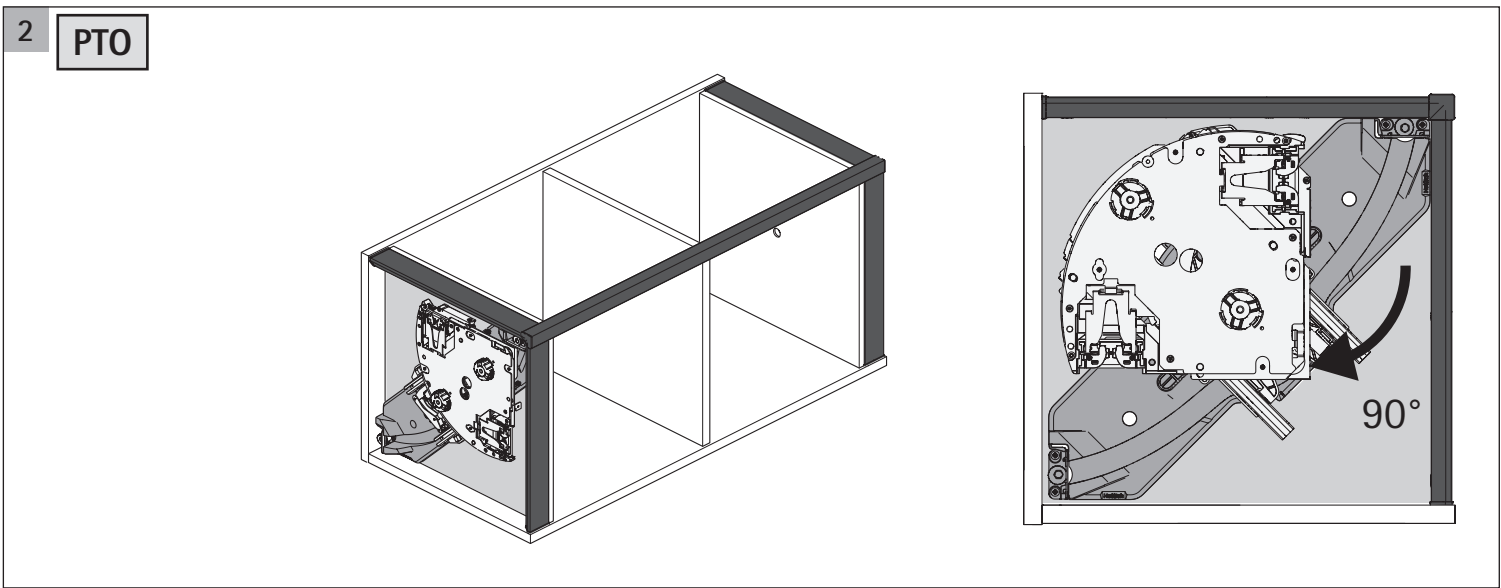
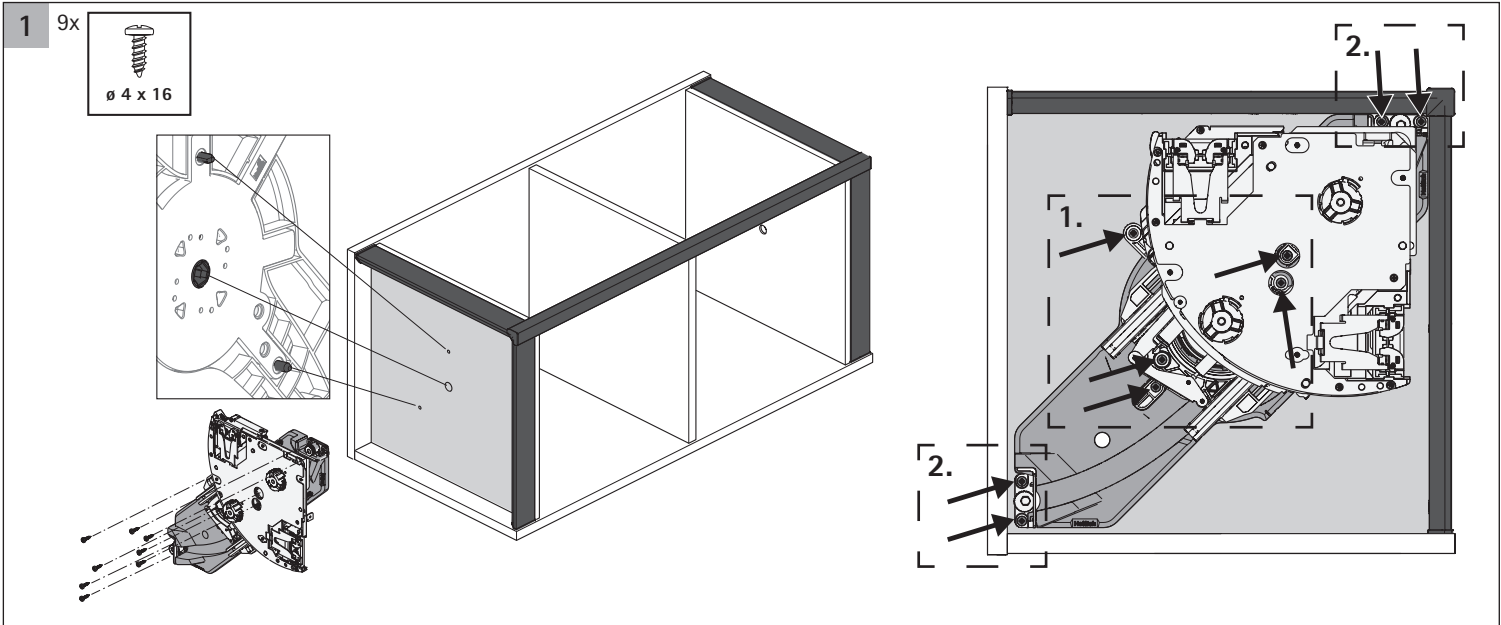
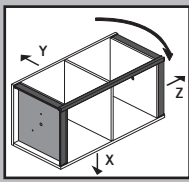

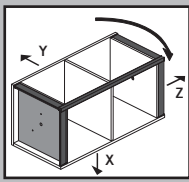

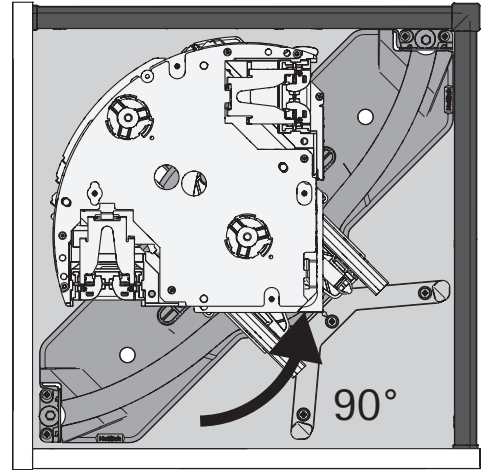
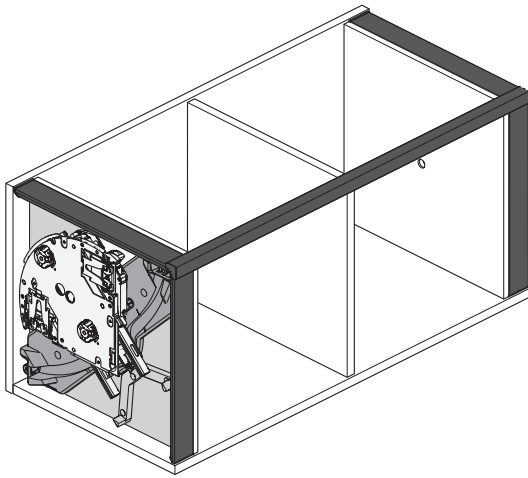

4 PTO



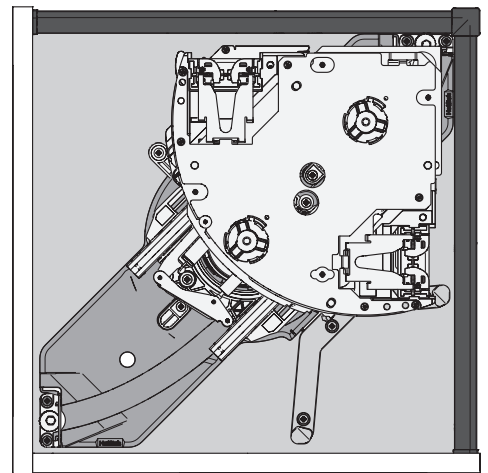
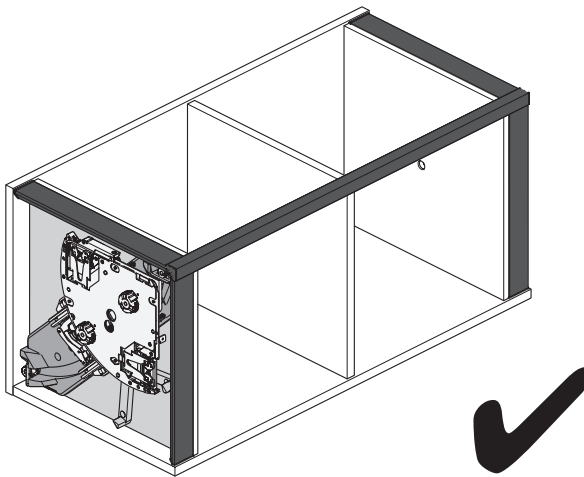

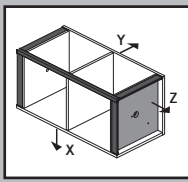
5



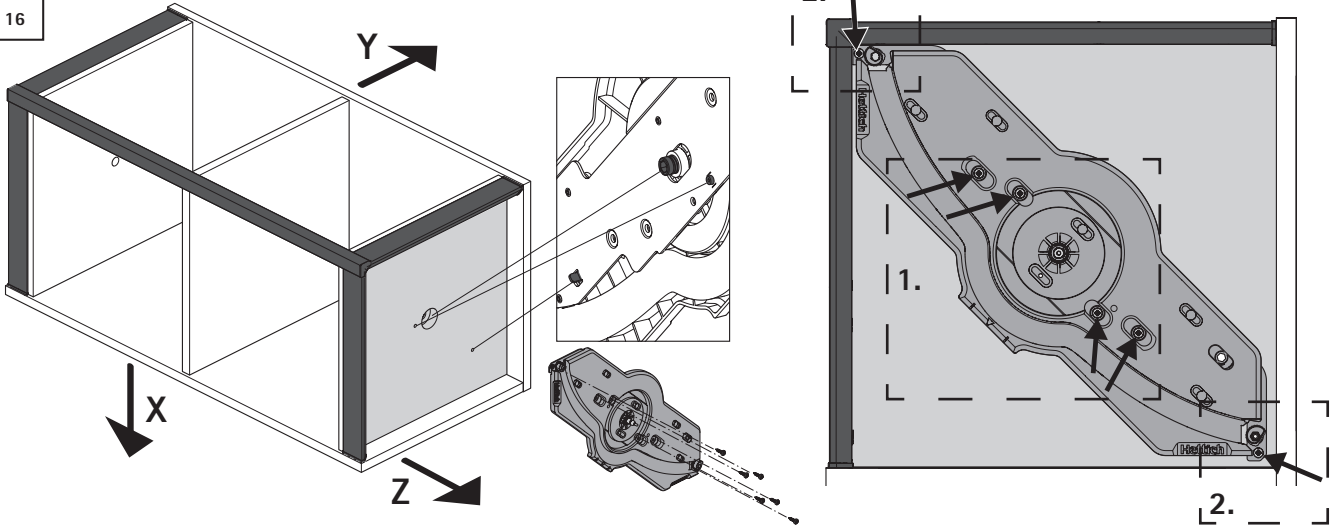

1 6x  $\varnothing 4 \times 16$



2 PTO 3x  $\varnothing 4 \times 16$

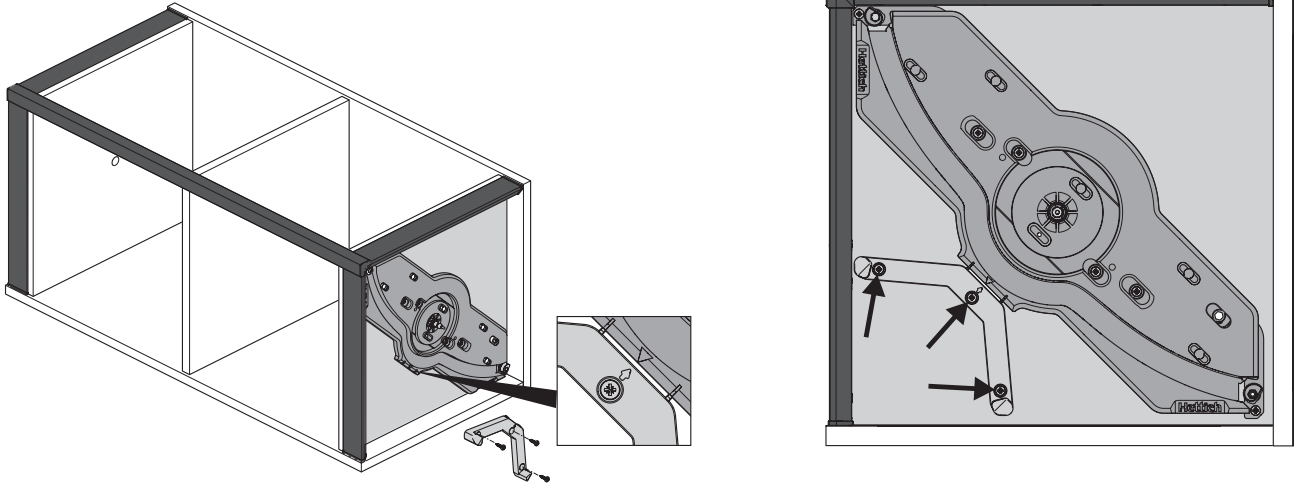

3

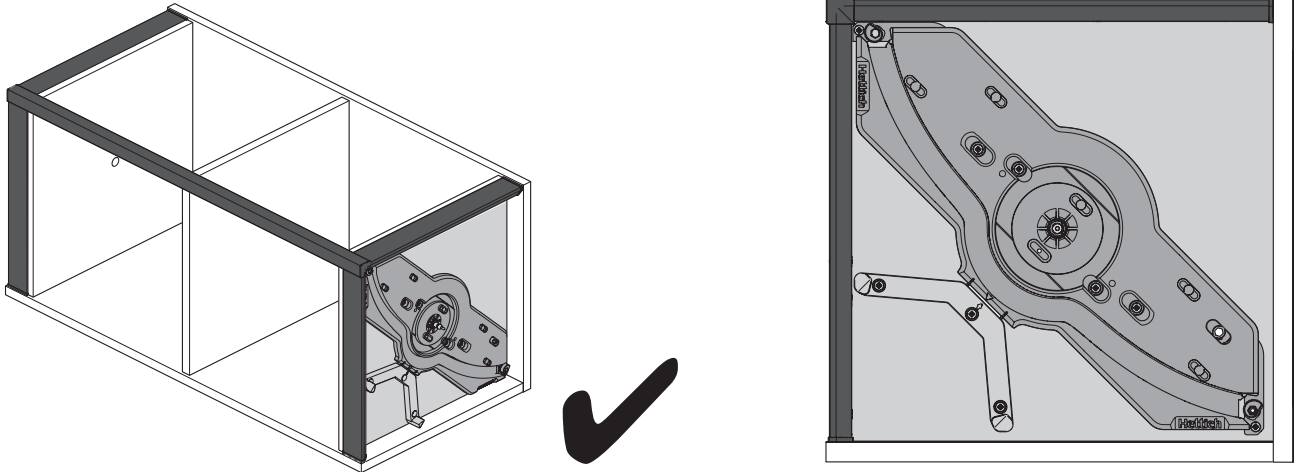

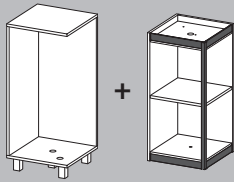

1

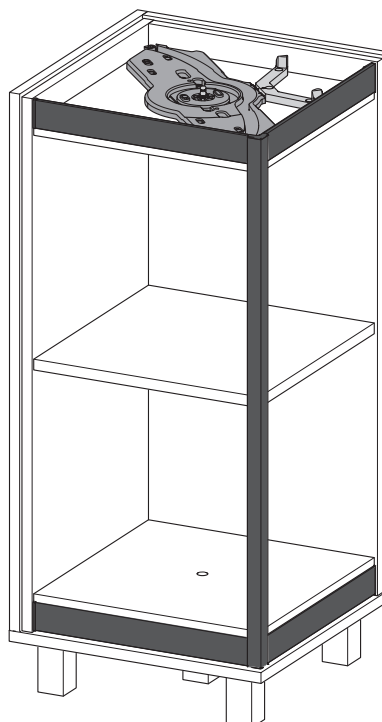
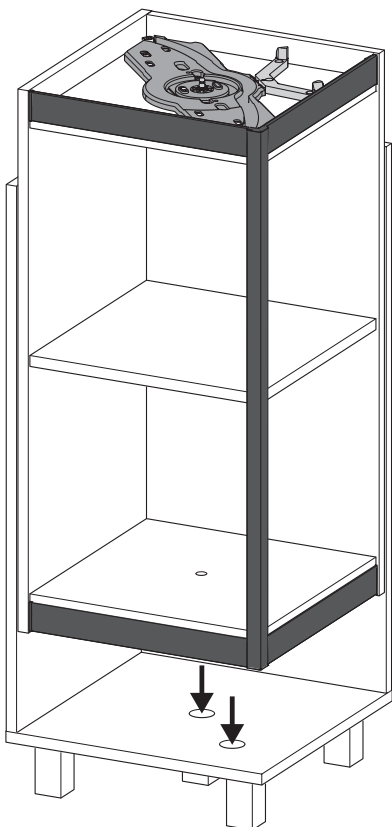
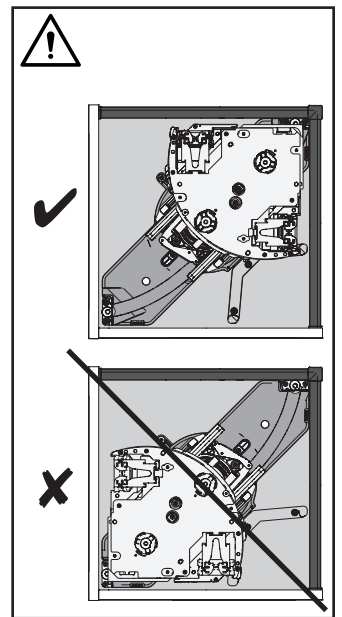
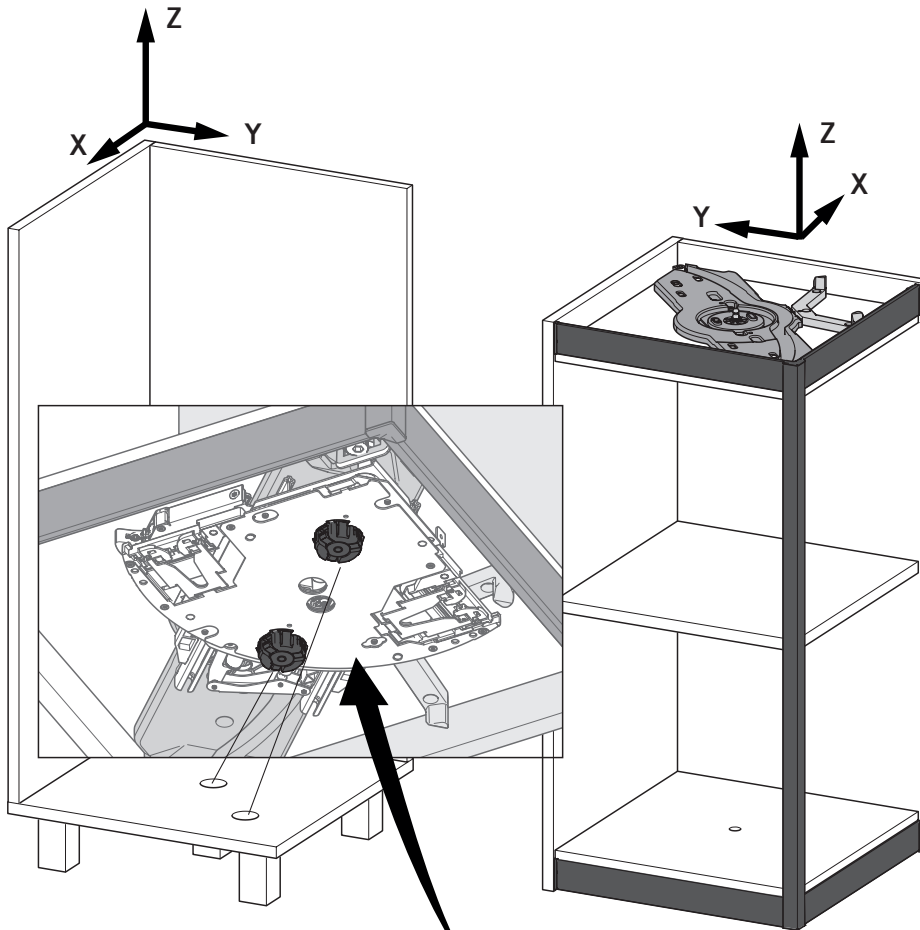

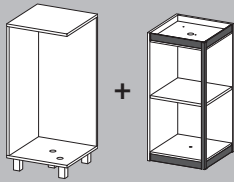

2

 ø 4 x 16	PTO
3x	PTO 1x
4x	-

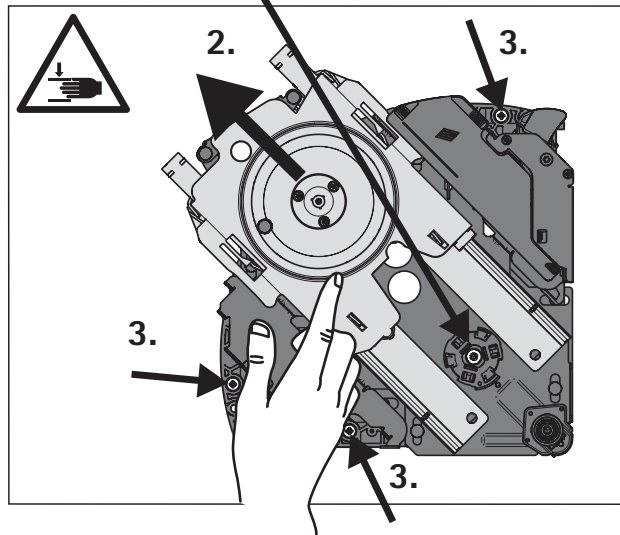
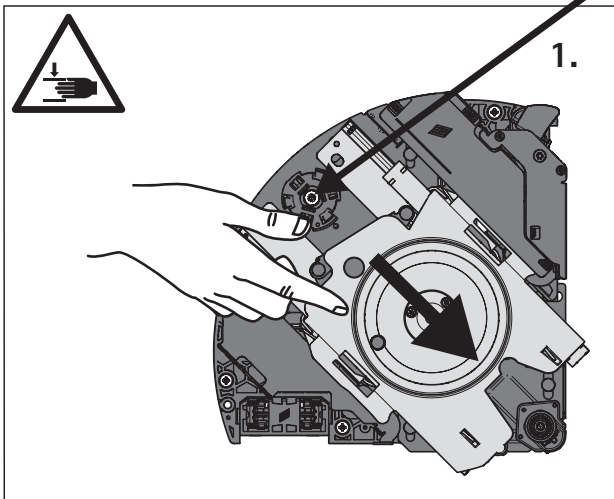
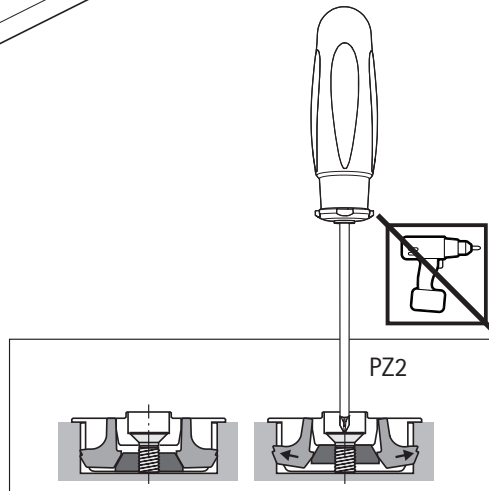
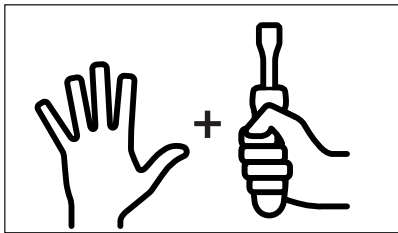
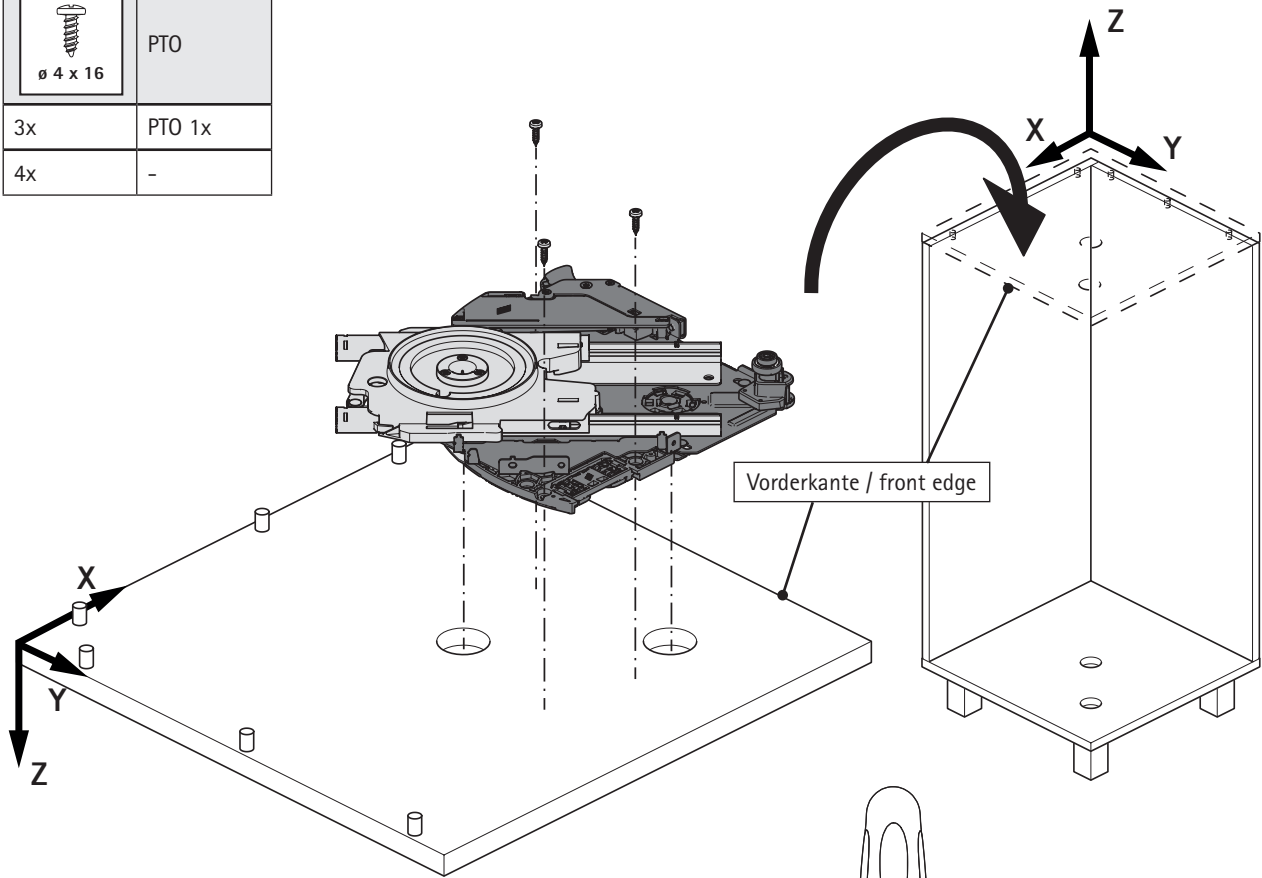

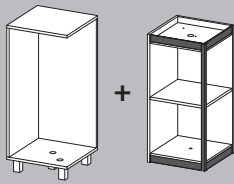

3

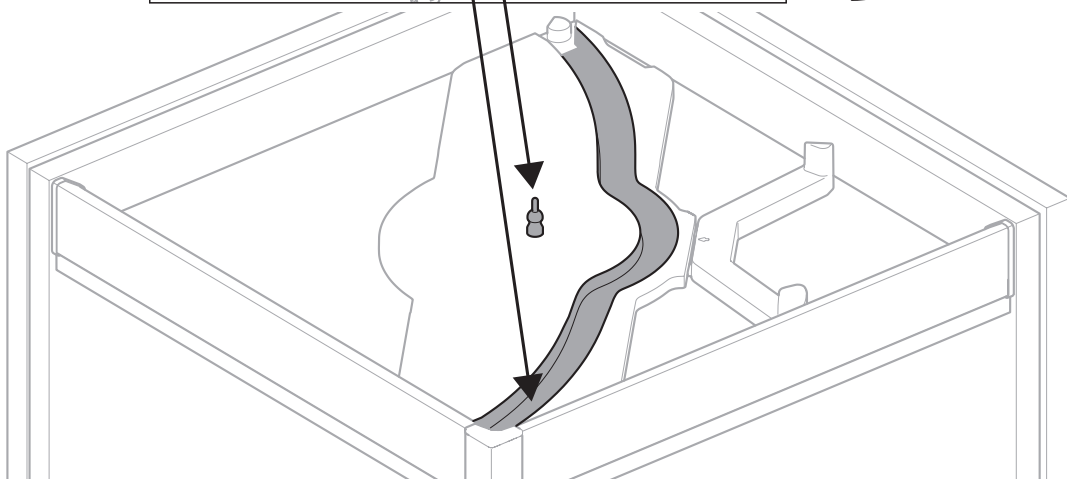
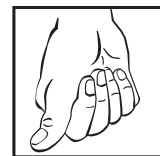
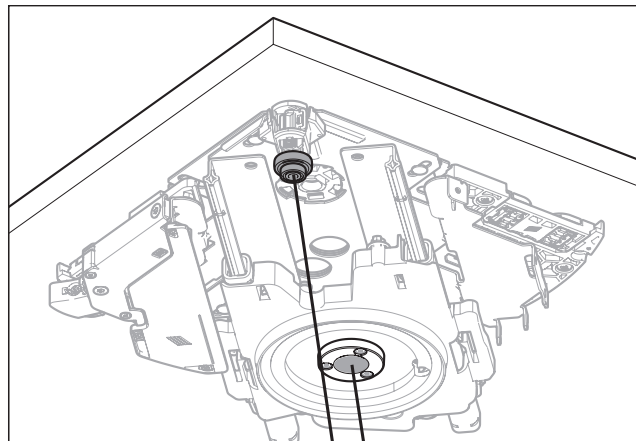
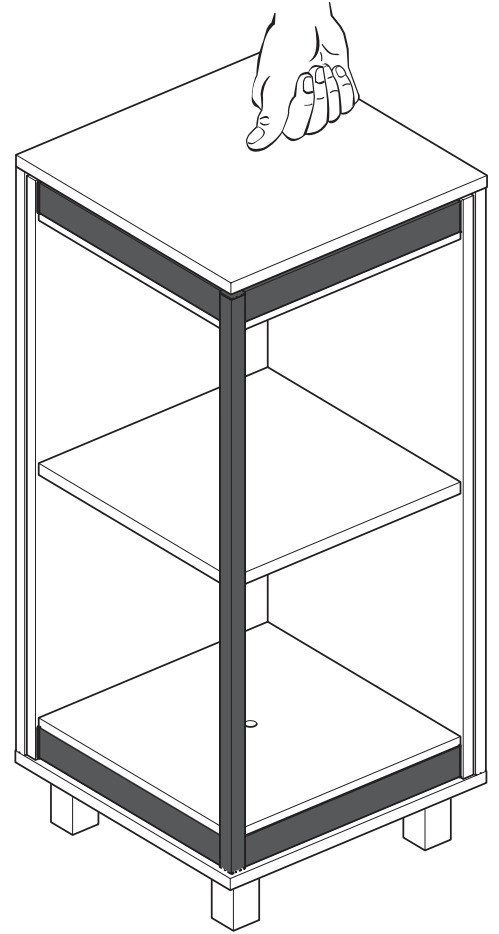
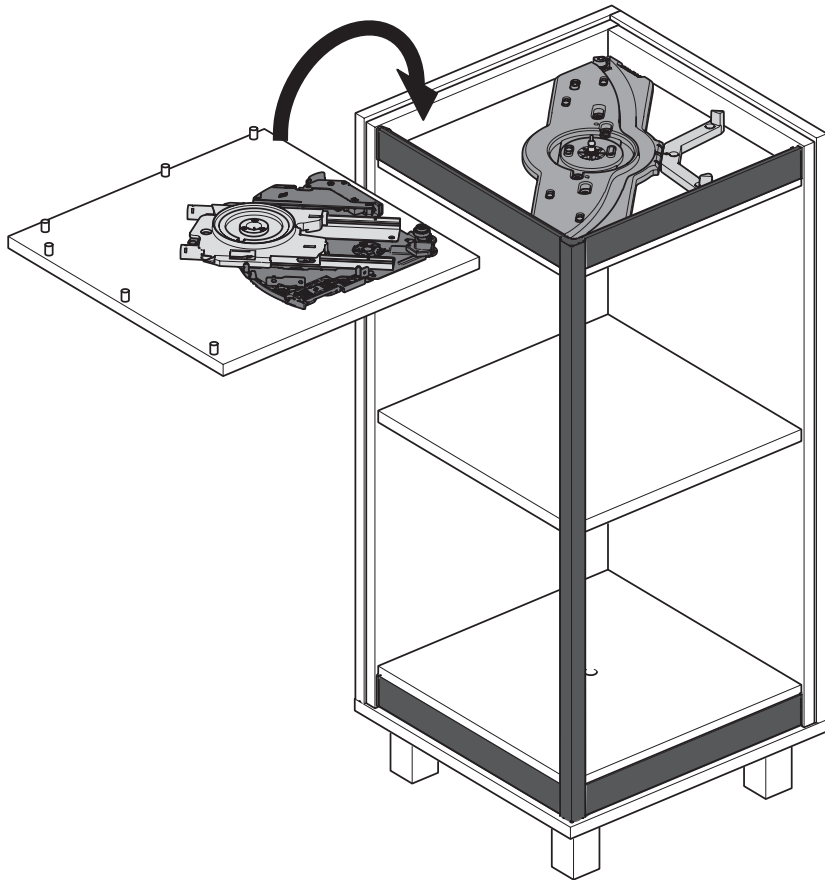

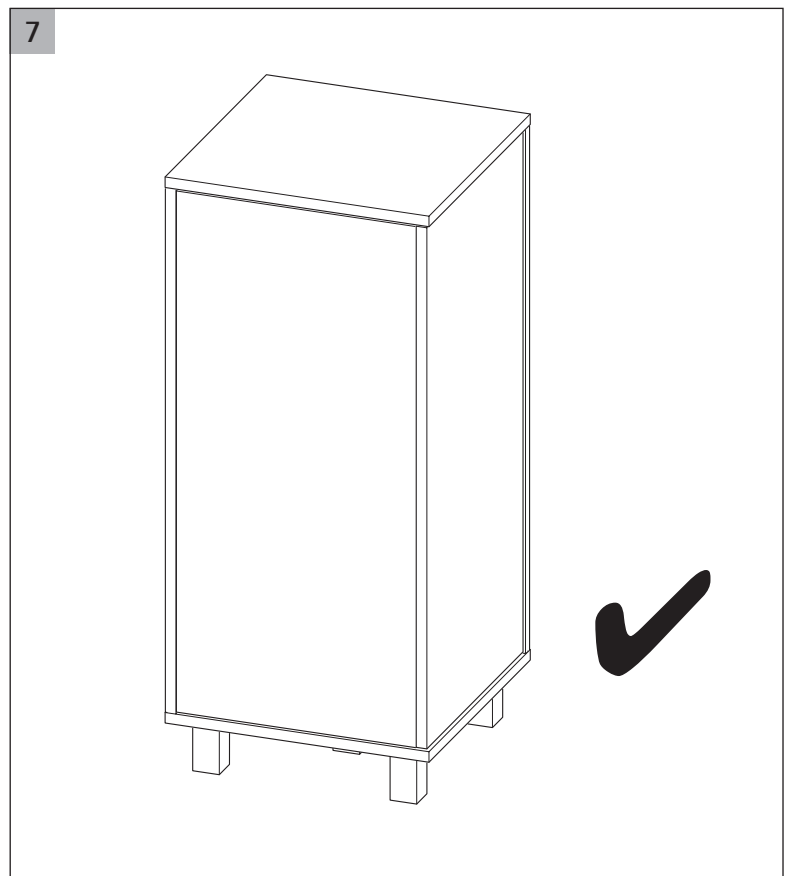
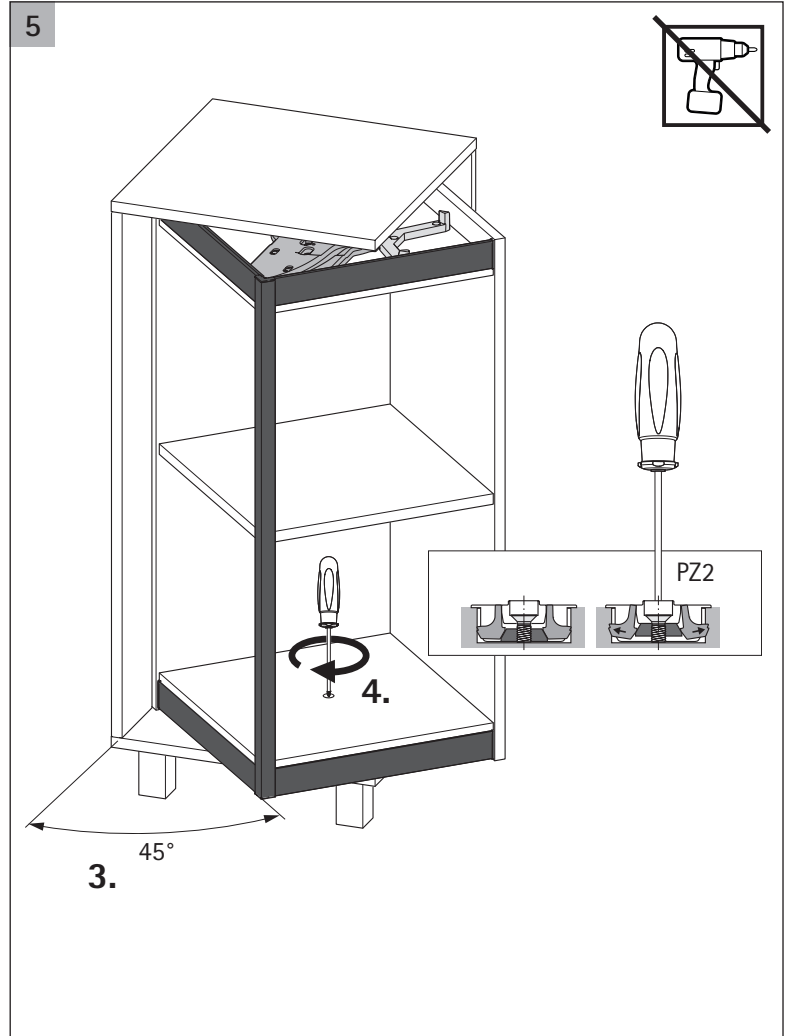
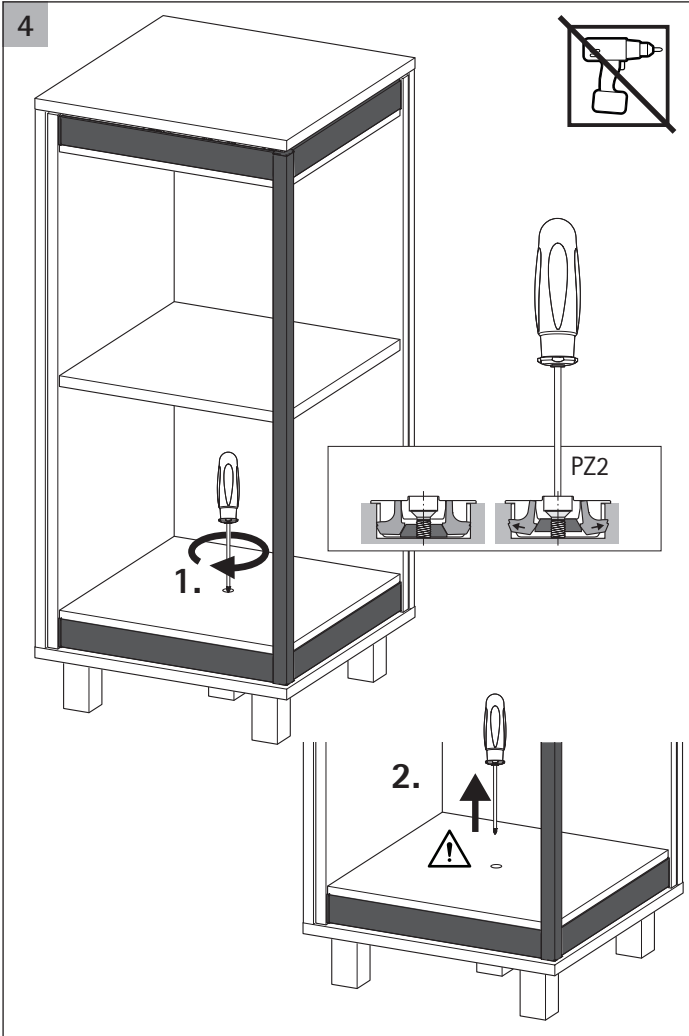
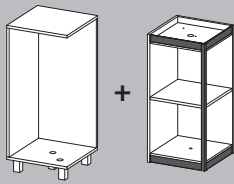

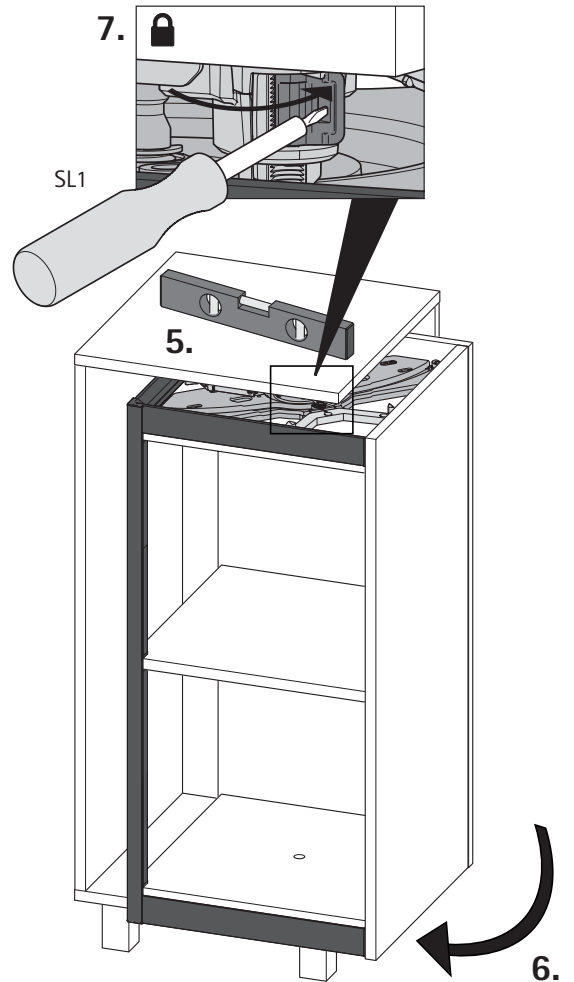
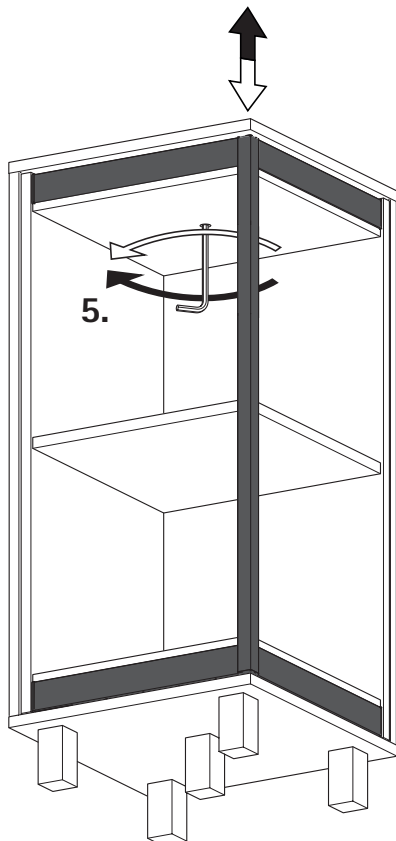
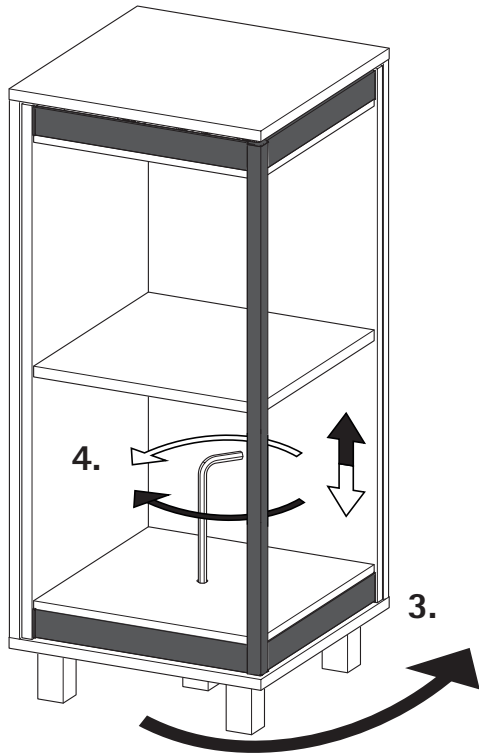
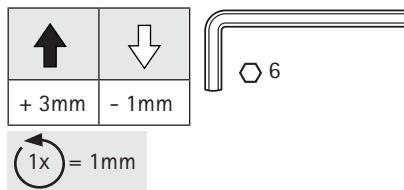
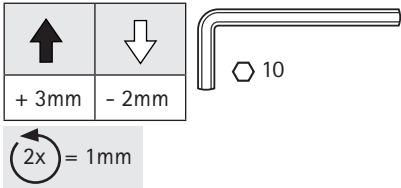
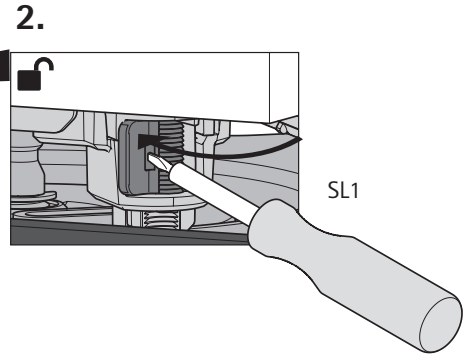
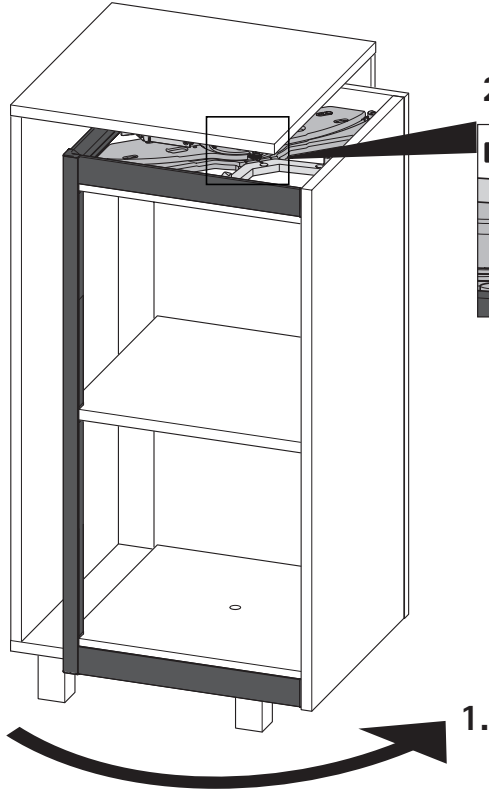
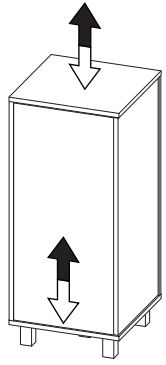
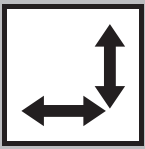

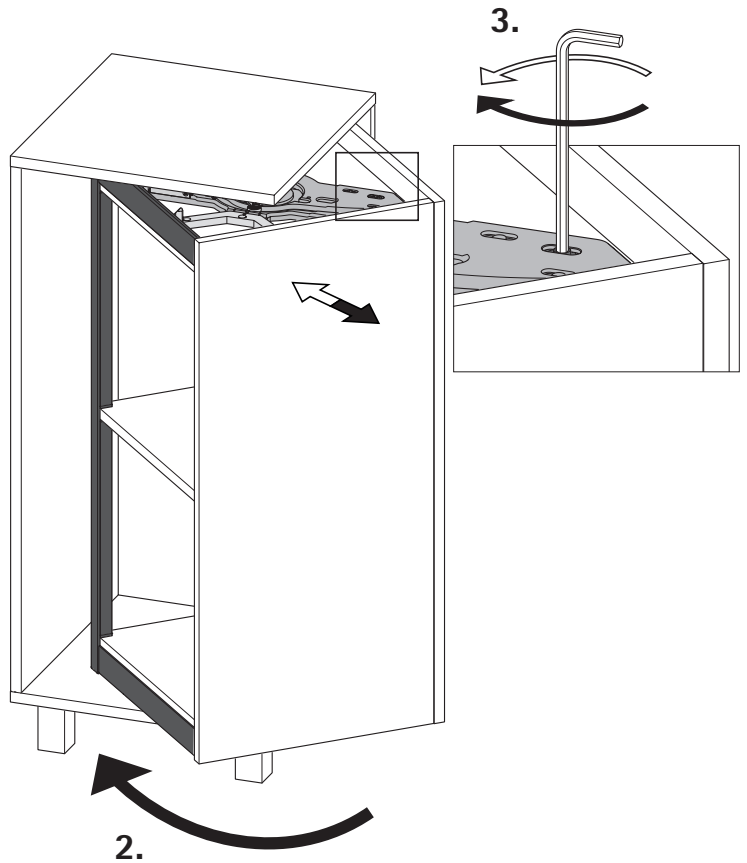
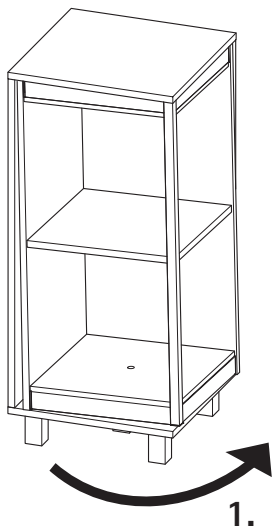
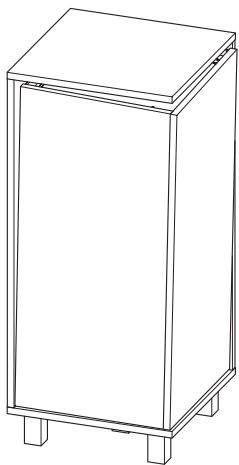
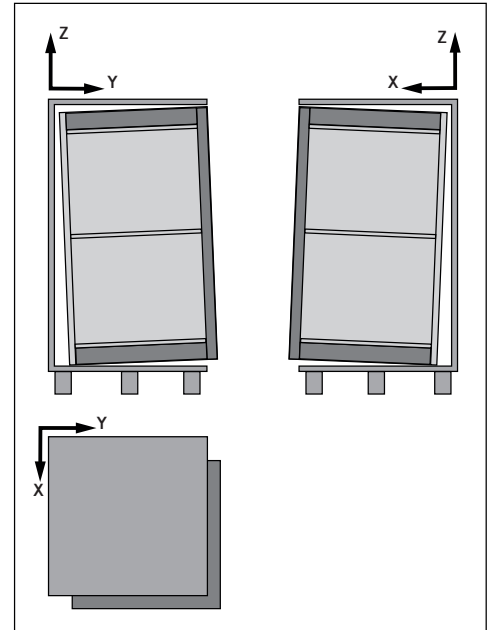
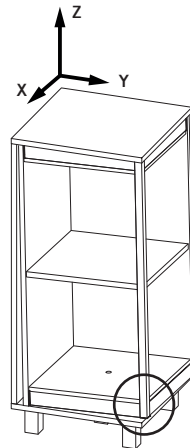
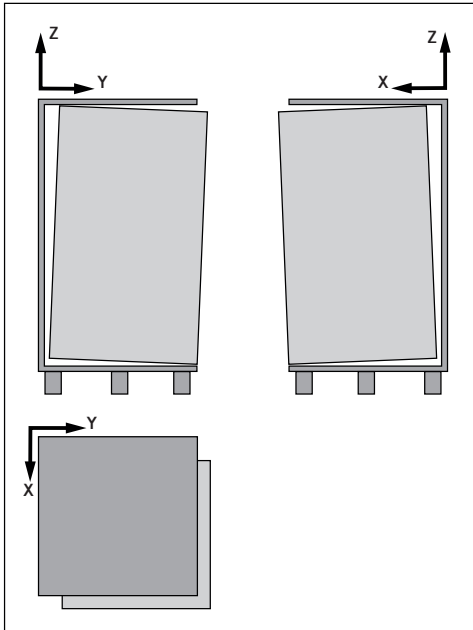
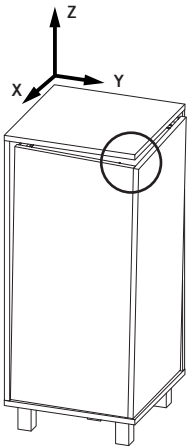
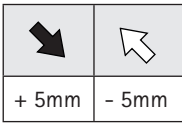
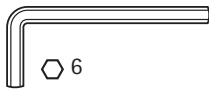
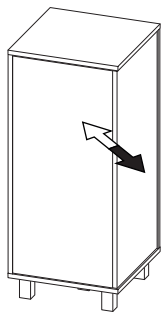
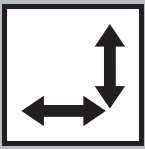

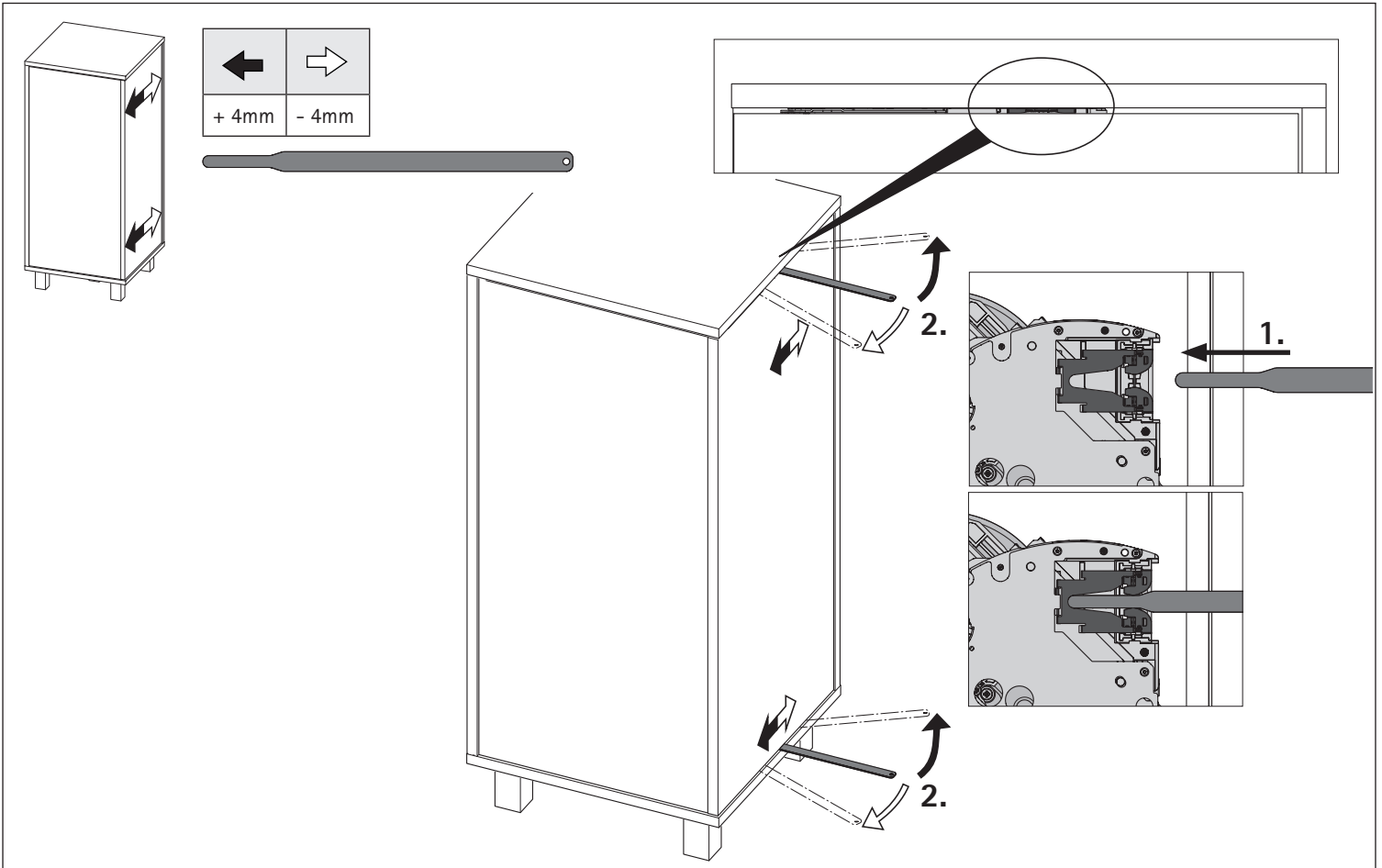
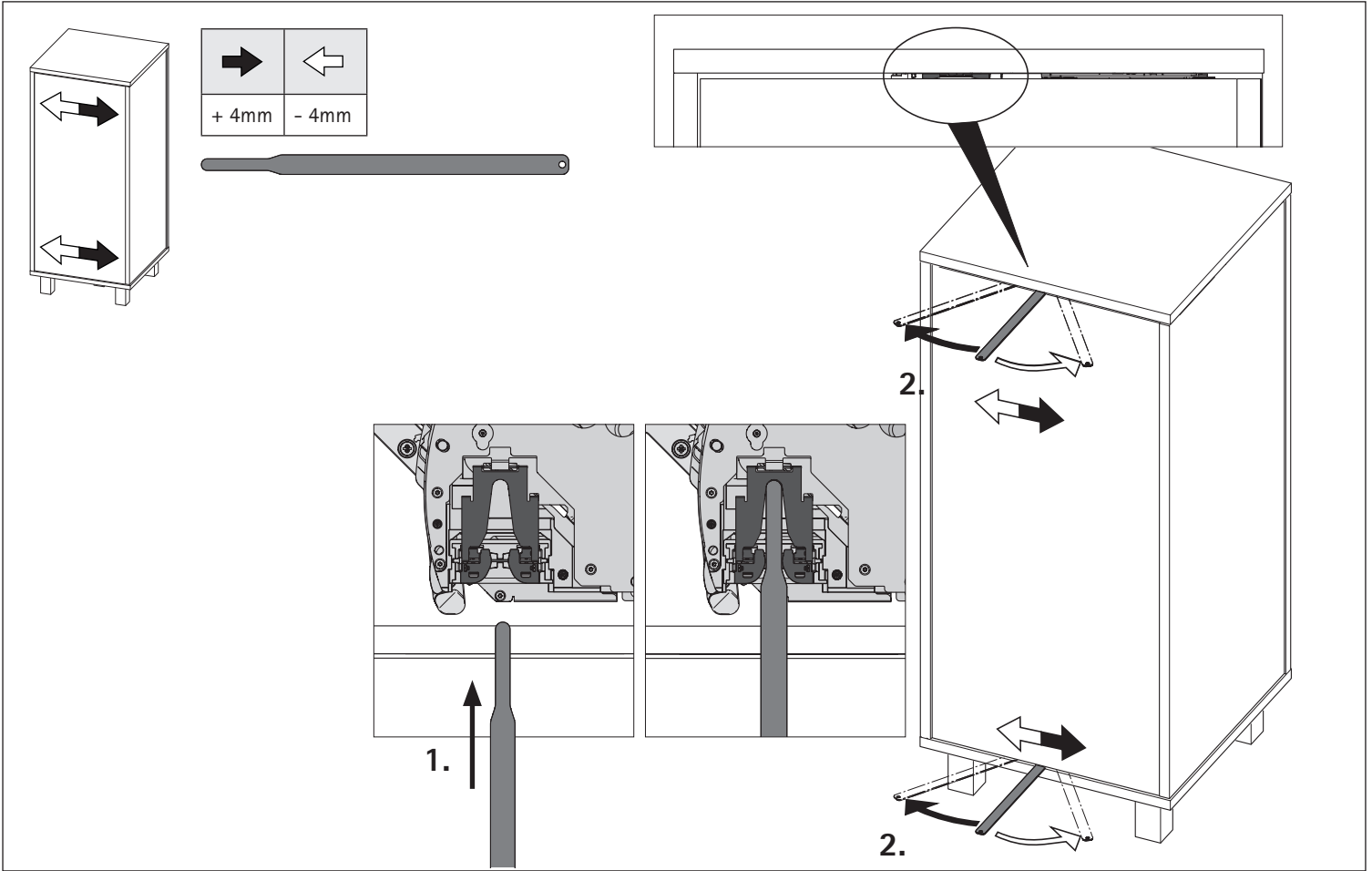
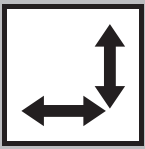

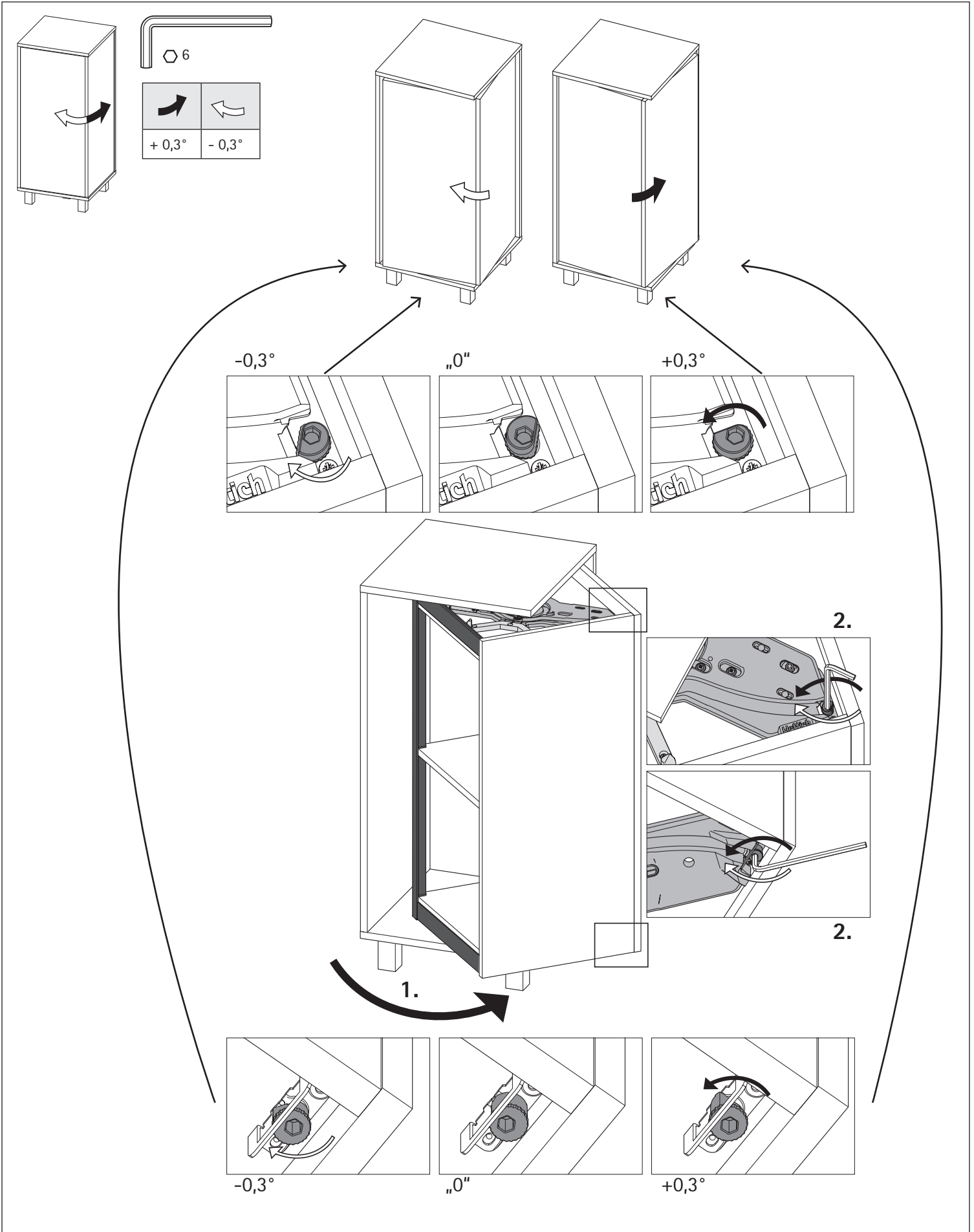
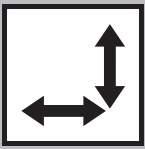

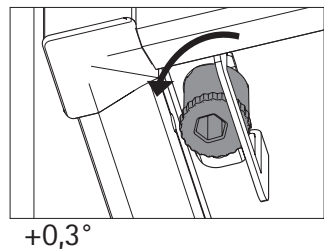
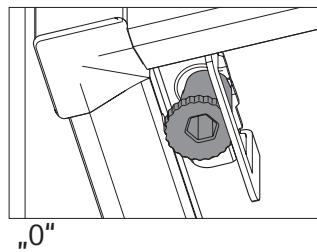
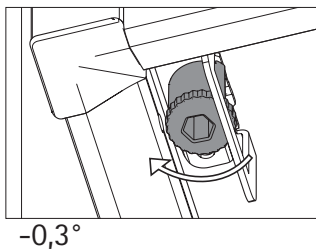
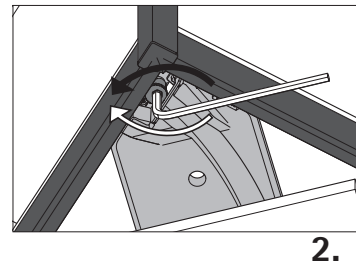
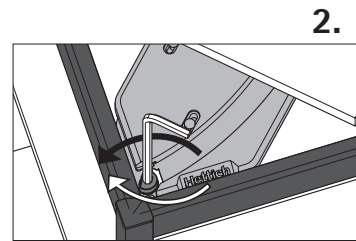
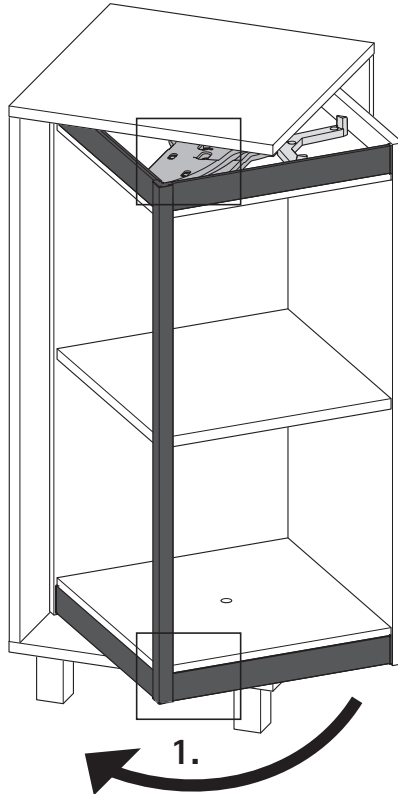
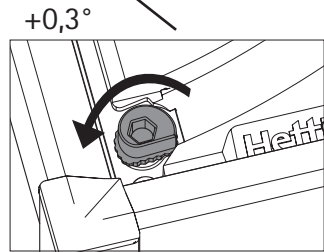
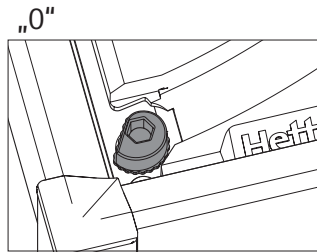
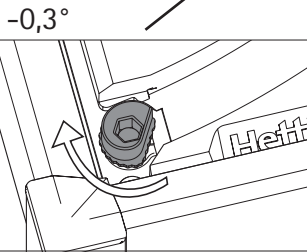
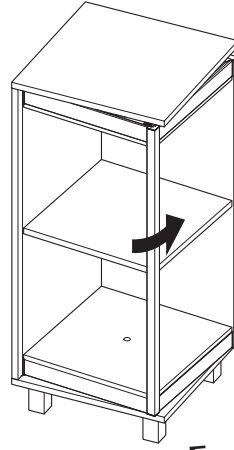
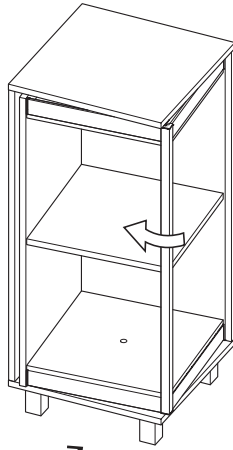
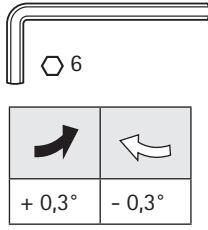
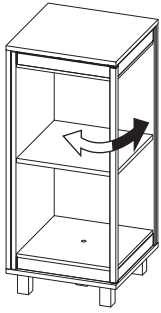
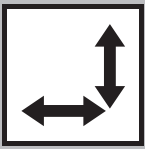

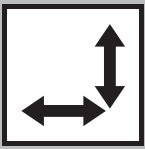

PTO

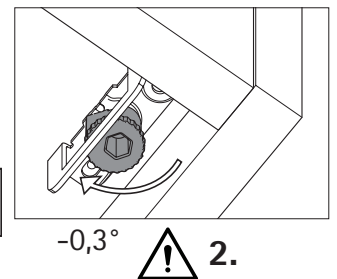
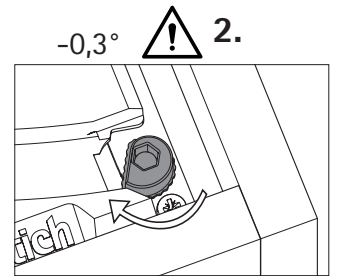
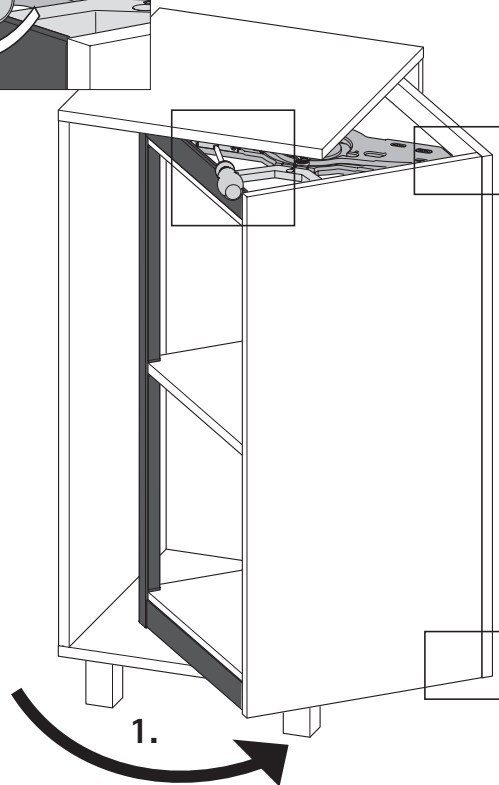
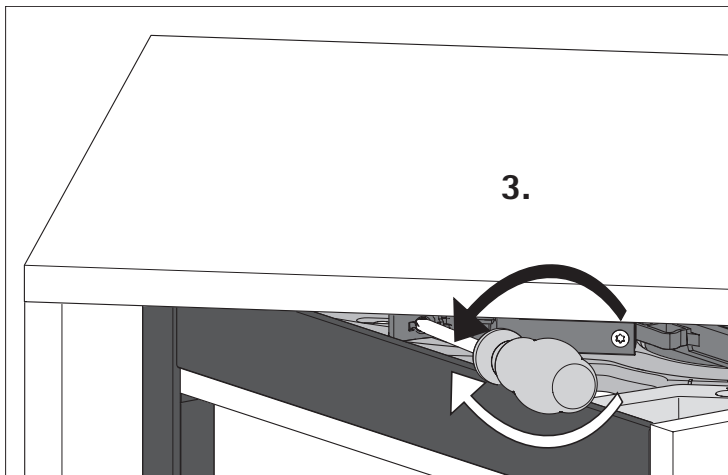
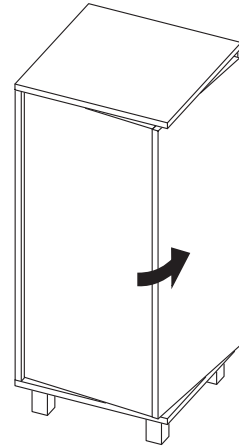
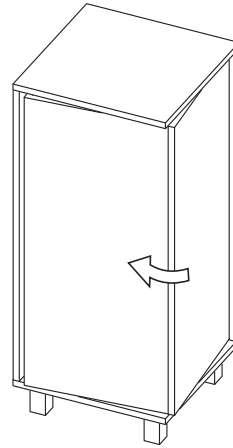
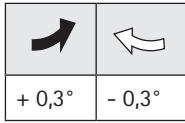
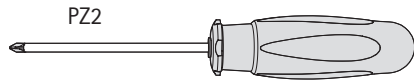
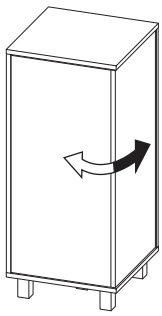

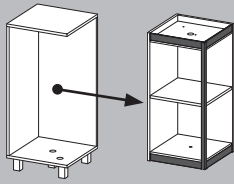

Demontage / disassembly

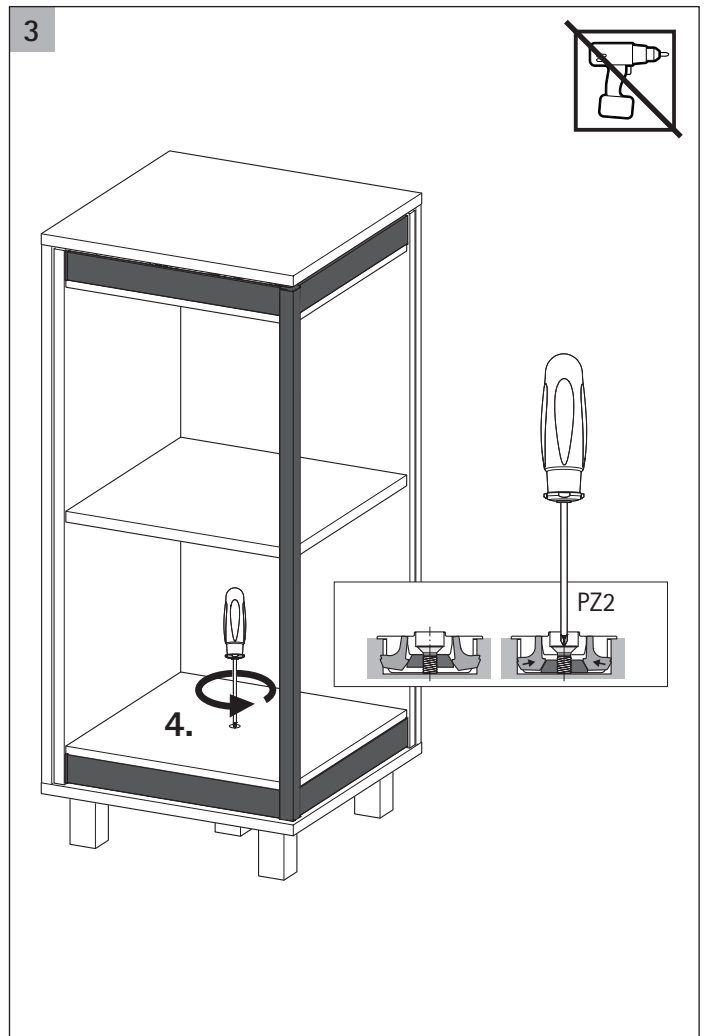
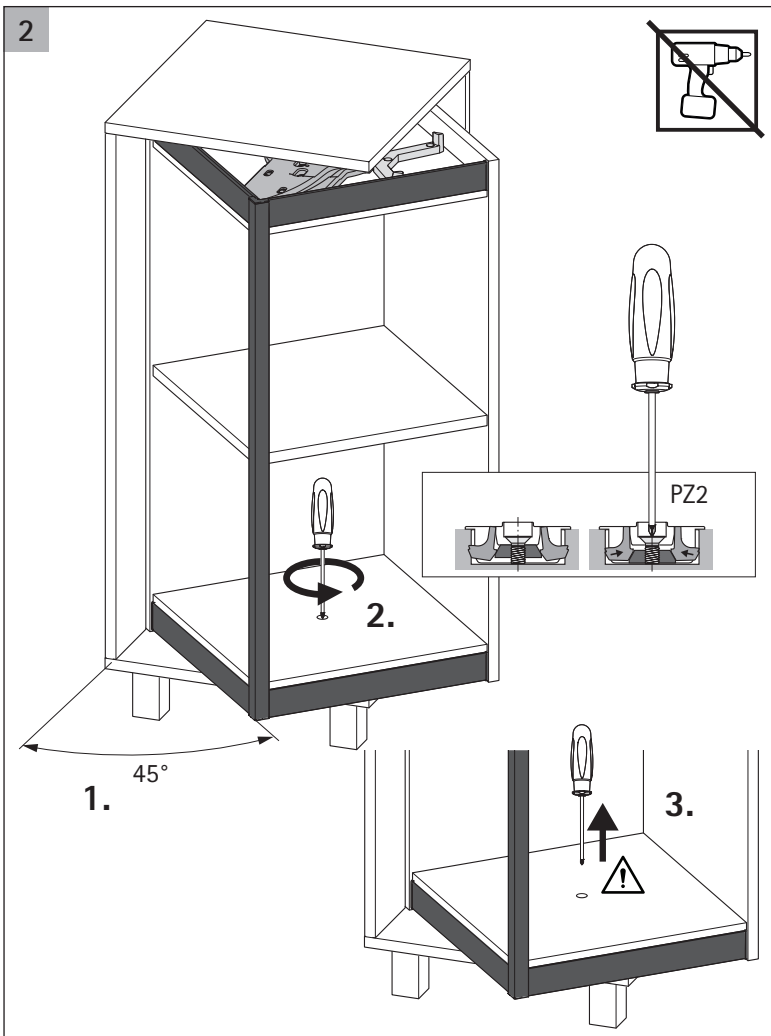
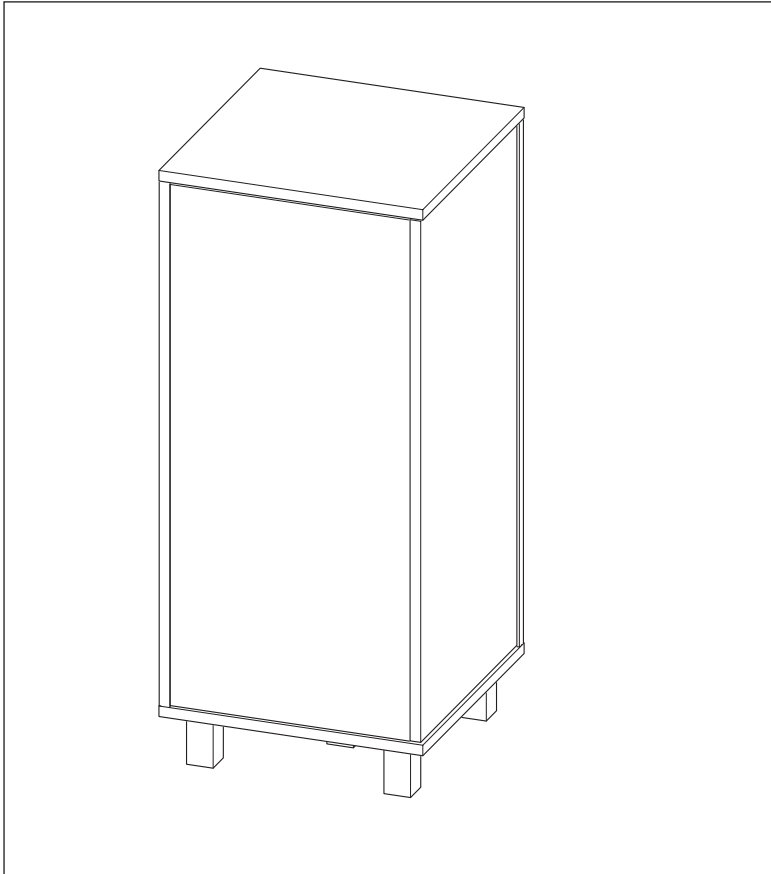

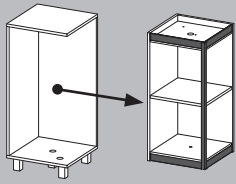

Demontage / disassembly

4

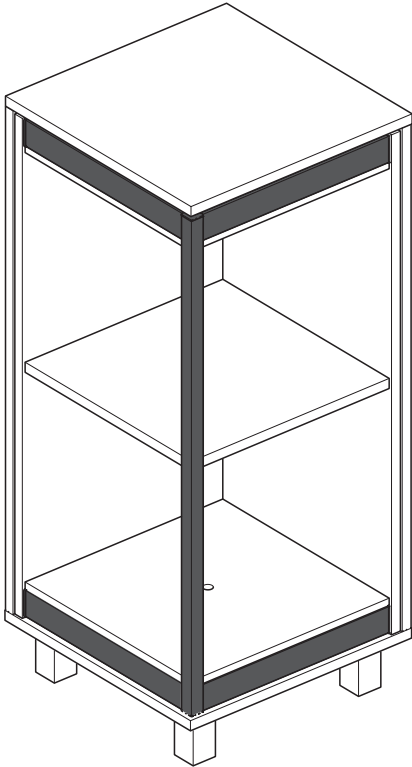

5

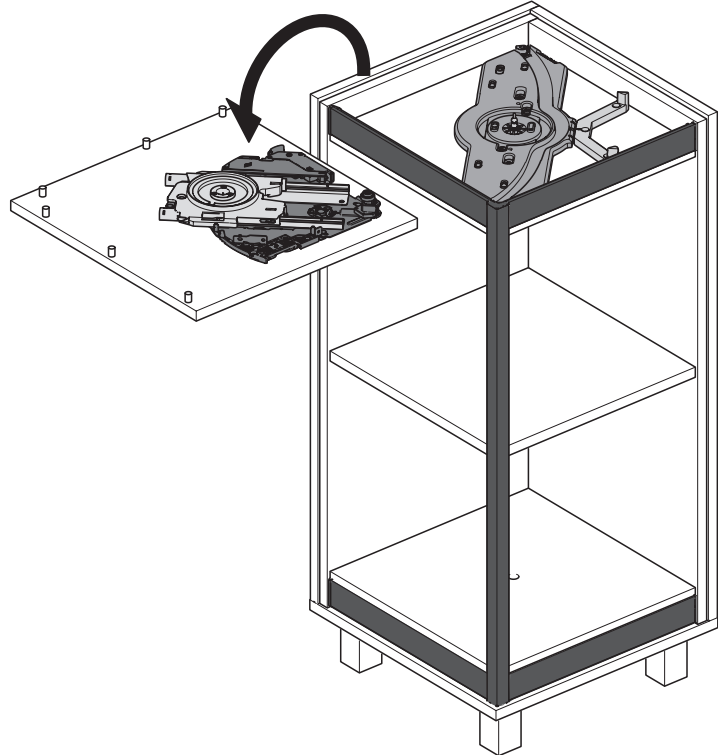

6

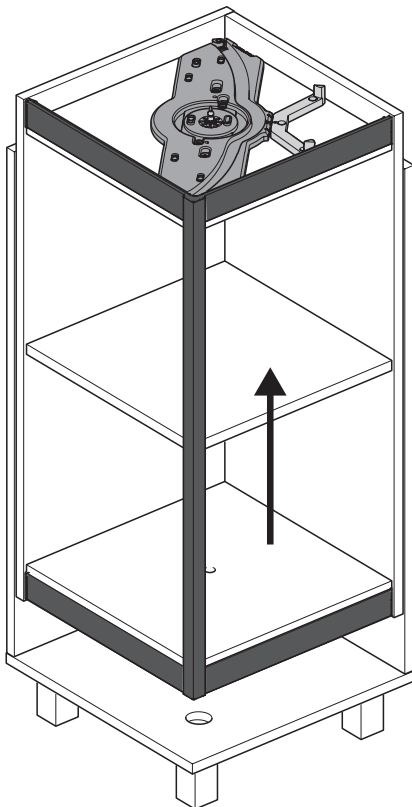

7

