

# Veosys

Stainless steel hinge



## Fast assembly concealed hinge

### ► Veosys with integrated Silent System



#### **The stainless steel hinge for the New Zealand outdoors.**

Its stainless steel finish makes the Veosys hinge from Hettich a robust all rounder. Not affected by temperature fluctuations and moisture, Veosys comes with tested

resistance to corrosion. With Hettich's integrated Silent System, the soft-closing functionality keeps working over a broad temperature range. And with its uniquely wide self closing angle of 35°, Veosys closes doors almost by itself.

# Fast assembly concealed hinge

- ▶ Veosys
- ▶ Range summary



Veosys 105° hinge  
105° opening angle

2 - 3



Mounting plates

4



Accessories

5



Technical information  
▶ fitting information

# Fast assembly concealed hinge

- ▶ Veosys 105° Stainless steel hinge
- ▶ 105° opening angle, drilling pattern TH 52 x 5.5 mm



- ▶ Concealed hinge with clip on installation and integrated Silent System
- ▶ Quality classification under EN 15570, Level 2
- ▶ Corrosion proof, 120h NSS (neutral salt spray test) to DIN EN ISO 9227
- ▶ For door thickness of 14 - 22 mm
- ▶ Cup diameter 35 mm
- ▶ Cup depth 11.5 mm
- ▶ Integrated overlay adjustment + 2.5 mm / - 2.5 mm
- ▶ Integrated depth adjustment + 2 mm / - 1.5 mm
- ▶ Height adjustment at mounting plate
- ▶ Stainless steel

<p>Drilling pattern</p>	<p>full overlay (Base B 11.5 mm)</p>	<p>half overlay (Base B 3 mm)</p>	<p>inset (Base B -6.5 mm)</p>
-------------------------	--	---------------------------------------	-----------------------------------

**With integrated Silent System, with self closing feature**

Cup assembly	Mounting hole $\varnothing \times T$ mm	Order no.			PU
		full overlay	half overlay	inset	
for screwing on	-	9 289 590	9 289 592	9 289 595	200 ea.

# Fast assembly concealed hinge

- ▶ Veosys 105° Stainless steel hinge
- ▶ 105° opening angle

## Minimum reveal per door

Door thickness mm	Cup distance C mm				
	3.0	4.0	5.0	6.0	7.0
14	0.3	0.3	0.2	0.2	0.2
15	0.5	0.5	0.4	0.4	0.4
16	0.7	0.7	0.6	0.6	0.5
17	0.9	0.9	0.9	0.8	0.8
18	1.2	1.1	1.1	1.1	1.0
19	1.5	1.4	1.4	1.3	1.3
20	1.8	1.8	1.7	1.6	1.6
21	2.2	2.1	2.0	2.0	1.9
22	2.6	2.5	2.4	2.4	2.3

Note:

The values in the table refer to doors with an edge radius of 1 mm.

On doors with other radii, the minimum reveal changes as follows:

Radius 0 mm:  
Values in table + 0.4 mm

Radius 3 mm:  
Values in table - 0.6 mm

## Protrusions / installed depth

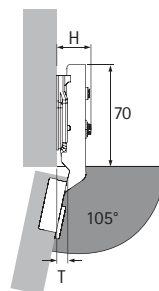

Hinge protrusion H / door protrusion T for distance D = 0 mm and cup distance C = 3 mm

Door mounting option	H mm	T mm
full overlay	20.0	7.5
half overlay	30.0	17.0
inset	37.0	24.0

## full overlay

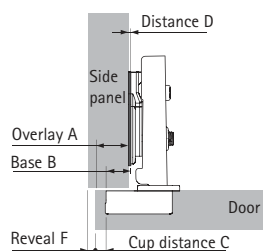

$$\text{Distance D} = \text{C} + \text{B} - \text{A}$$

$$= \text{cup distance C} + 11.5 \text{ mm} - \text{overlay A}$$

Overlay mm	Cup distance C mm				
	3.0	4.0	5.0	6.0	7.0
Distance D mm					
10	4.5	5.5	6.5	7.5	8.5
11	3.5	4.5	5.5	6.5	7.5
12	2.5	3.5	4.5	5.5	6.5
13	1.5	2.5	3.5	4.5	5.5
14	0.5	1.5	2.5	3.5	4.5
15		0.5	1.5	2.5	3.5
16			0.5	1.5	2.5
17				0.5	1.5
18					0.5

## half overlay

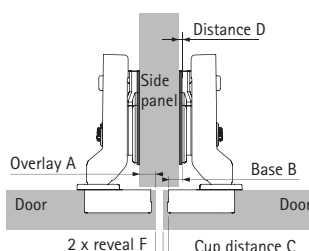

$$\text{Distance D} = \text{C} + \text{B} - \text{A}$$

$$= \text{cup distance C} + 3 \text{ mm} - \text{overlay A}$$

Overlay mm	Cup distance C mm				
	3.0	4.0	5.0	6.0	7.0
Distance D mm					
0.5	5.5	6.5	7.5	8.5	9.5
1.5	4.5	5.5	6.5	7.5	8.5
2.5	3.5	4.5	5.5	6.5	7.5
3.5	2.5	3.5	4.5	5.5	6.5
4.5	1.5	2.5	3.5	4.5	5.5
5.5	0.5	1.5	2.5	3.5	4.5
6.5		0.5	1.5	2.5	3.5
7.5			0.5	1.5	2.5
8.5				0.5	1.5
9.5					0.5

## inset

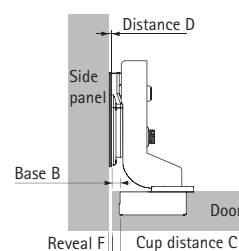

$$\text{Distance D} = \text{C} + \text{B} + \text{F}$$

$$= \text{cup distance C} - 6.5 \text{ mm} + \text{reveal F}$$

Door thickness mm	Cup distance C mm				
	3.0	4.0	5.0	6.0	7.0
Distance D mm					
14				0.7	
15				0.9	
16			0.1	1.0	
17			0.3	1.3	
18			0.6	1.5	
19			0.8	1.8	
20		0.2	1.1	2.1	
21		0.5	1.5	2.4	
22	0.0	0.9	1.9	2.8	

## Useful information

- ▶ For mounting plates and accessories, see page 4 - 5
- ▶ For mounting options, assembly information, installation instructions and quality criteria, see page 6 - 8

## Fast assembly concealed hinge

- ▶ Stainless steel mounting plates with oblong hole height adjustment
- ▶ For Veosys

### Cross mounting plate for screwing on

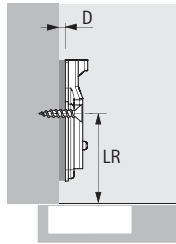

- ▶ For 4.5 mm  $\varnothing$  x 16 mm countersunk screws
- ▶ Quality classification under EN 15570, Level 2
- ▶ Hole spacing 32 mm
- ▶ Oblong hole height adjustment  $\pm 3$  mm
- ▶ Stainless steel

Hole line distance LR mm	Order no. / Distance D mm		PU
	0.0	2.0	
37	9 289 598	9 289 609	200 ea.

# Fast assembly concealed hinge

- ▶ Accessories
- ▶ For Veosys

## Cover cap for Veosys hinge arm



- ▶ Suitable for use with Veosys
- ▶ Stainless steel

Version	Order no.	PU
embossed with Hettich logo	<b>9 289 610</b>	200 ea.
neutral	<b>9 289 611</b>	200 ea.

## Adapter for reducing drilling depth

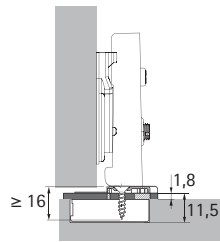

- ▶ To reduce the required depth of the cup drilling in thin or highly softened doors
- ▶ Can be used with hinge cup for screwing on
- ▶ The gap between cabinet body and door increases by the thickness of the adapter
- ▶ Attachment by  $\varnothing 4 \times 16$  mm countersunk screws
- ▶ Transparent plastic
- ▶ Design for drilling pattern TH
- ▶ Thickness 1.8 mm

Order no.	PU
<b>9 306 263</b>	50 ea.

## Parallel adaptor for cross mounting plates

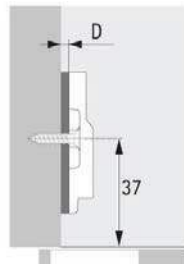

- ▶ For increasing mounting plate distance
- ▶ A trial mounting is recommended
- ▶ Plastic, grey

Distance D mm	Order no.	PU
<b>3,0</b>	<b>9 306 263</b>	50 ea.

Can only be used with Veosys cross mounting plates for screwing on, screw length is defined by the specific configuration

# Technical information

- ▶ Veosys
- ▶ Fitting information

### Full overlay door

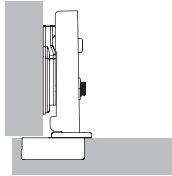

The door is in front of the cabinet side and only a small gap remains at the side within which the door can open reliably. Alternatively, the door can also be fully overlaid. In this case sufficient space must be allowed at the side for the required minimum reveal. Straight hinges are used.

### Half overlay door

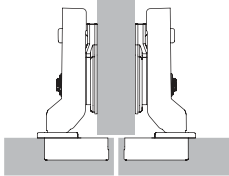

This is where two doors are positioned in front of a cabinet centre panel, with the required overall reveal between them (at least 2 x minimum reveal). In other words, each door has a smaller overlay and cranked hinges are therefore used.

### Inset door

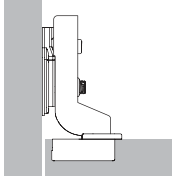

The door is positioned inside the cabinet body, i.e. next to the cabinet body side. Here too, a gap is needed so that the door can open reliably. Highly cranked hinges are used here. For an inset door, the mounting plate must be set back by the thickness of the door + 1 mm as well as by any chosen door offset.

### Minimum reveal

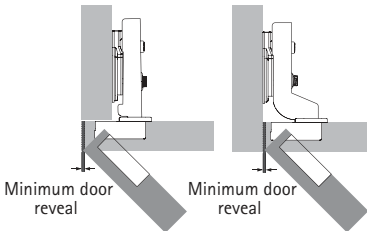

**For overlay and inset door**  
The minimum reveal (also known as the door clearance or minimum clearance) is the space required at the side for opening the door. The size of the minimum reveal depends on the cup distance C, the door thickness and the type of hinge selected. Radii on the door edges reduce the door clearance. The minimum reveal is shown in the table for the respective hinge types.

### Minimum reveal

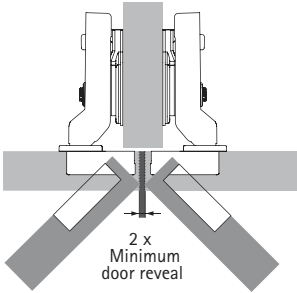

**For half overlay doors**  
The total reveal selected between the doors must be at least twice the door clearance. Both doors can then be opened at the same time.

### Cup distance C

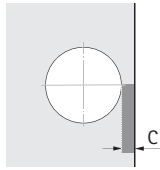

Cup distance C is the distance between door edge and the edge of the cup drilling. The greater the distance selected for cup distance C, the smaller door clearance will be, i.e. the minimum reveal required.

### Overlay / Base

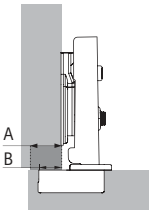

Overlay refers to the projection of the door in front of the cabinet body side. Base refers to the projection of the cup in front of the cabinet body side for a mounting plate distance of 0 mm.

A = Overlay  
B = Base

### Number of hinges per door

Door width, height and weight as well as the material quality of the door are decisive factors determining the number of hinges required.

The factors encountered in practice differ widely from case to case. For this reason, the number of hinges specified in the diagram must be understood as a guide only. If in doubt, it is recommended to carry out a trial mounting and adjust the number of hinges as necessary. For reasons of stability, space X between the hinges must always be made as large as possible. Distance X must be at least 280 mm.

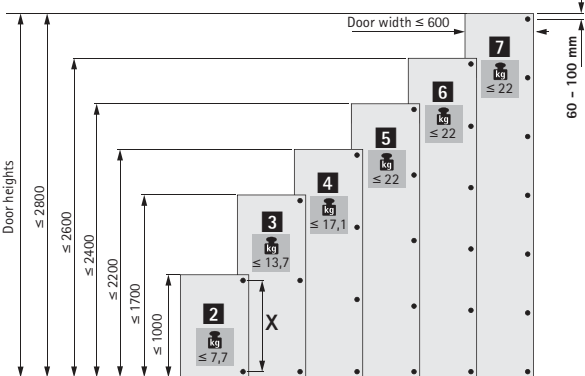

Door height (mm)	Door weight (kg)	Number of hinges
≤ 1000	≤ 7,7	2
≤ 1700	≤ 13,7	3
≤ 2200	≤ 17,1	4
≤ 2400	≤ 22	5
≤ 2600	≤ 22	6
≤ 2800	≤ 22	7

Door width ≤ 600 mm  
Door height range: 60 - 100 mm  
Distance X between hinges: ≥ 280 mm



# Technical information

- ▶ Veosys
- ▶ Fitting information

## General calculation of distances

Mounting plates are available in various distances. The effective height of the mounting plate is defined by distance D. Distance D is embossed on the top of each mounting plate. A larger distance D reduces the overlay for full and half overlay applications. On inset doors, a larger distance D increases the door reveal. Before determining the required distance, check whether the desired reveal is equal to or greater than

the required minimum reveal. If the desired reveal is less than the required minimum reveal, the required minimum reveal can be reduced by increasing cup distance C or by producing radii on the door edges.

### Calculation of distances

#### For overlay and half overlay doors

The required distance D can be determined after checking the minimum reveal. Ideally, door overlay and cup distance should be selected to produce distance D that is available as mounting plate.

#### Example: Distance determined using the table

Overlay = 14 mm and cup distance C = 4.5 mm yield a distance of 3.0 mm.

#### Example: Distance determined using the calculation formula

Hinge for overlay door, basis B = 12.5 mm  
 Distance D = Cup distance C + Basis B - Overlay A  
 Distance D = 4.5 mm + 12.5 mm - 14 mm = 3.0 mm

Intermediate distances not available as mounting plate distances are achieved by adjusting the hinge overlay.

Overlay mm	Cup distance C mm					
	3,0	4,0	4,5	5,0	6,0	7,0
	Distance D mm					
10	5,5	6,5	7,0	7,5	8,5	9,5
11	4,5	5,5	6,0	6,5	7,5	8,5
12	3,5	4,5	5,0	5,5	6,5	7,5
13	2,5	3,5	4,0	4,5	5,5	6,5
14	1,5	2,5	3,0	3,5	4,5	5,5
15	0,5	1,5	2,0	2,5	3,5	4,5
16		0,5	1,0	1,5	2,5	3,5
17			0,0	0,5	1,5	2,5
18					0,5	1,5
19						0,5

### Calculation of distances

#### For inset doors

When calculating the mounting plate distance using the table for inset doors, allowance is automatically made for the reveal that is shown as the minimum reveal produced by cup distance C and door thickness in the table of minimum reveals. If a reveal is to be produced that is larger than this minimum reveal, select a mounting plate distance of the appropriate size.

#### Example: Distance determined using the table

From the table, a door thickness = 20 mm and cup distance C = 4.5 mm produces a mounting plate distance of 1.5 mm. This creates the required minimum reveal of 1 mm, for example. If a reveal of 2.5 mm is required instead, select a mounting plate distance 1.5 mm larger. In this example, that means a distance of 3 mm instead of 1.5 mm.

#### Example: Distance determined using the calculation formula

Hinge for inset application, basis B = - 4 mm  
 Distance D = cup distance C + basis B + reveal F  
 Distance D = 4.5 mm - 4 mm + 1 mm = 1.5 mm

Intermediate values not available as mounting plate distances are achieved by adjusting the hinge overlay.

Door thickness mm	Cup distance C mm					
	3,0	4,0	4,5	5,0	6,0	7,0
	Distance D mm					
15		0,2	0,7	1,2	2,2	3,2
16		0,3	0,8	1,3	2,3	3,3
17		0,4	0,9	1,4	2,4	3,4
18		0,6	1,1	1,6	2,6	3,5
19		0,8	1,3	1,8	2,7	3,7
20	0,1	1,0	1,5	2,0	3,0	3,9
21	0,4	1,3	1,8	2,3	3,2	4,2
22	1,2	1,8	2,2	2,6	3,6	4,5

# Quality criteria

## ► Concealed hinges

### Quality that meets all the demands

#### Quality that meets all the demands

The quality of hinges is subject to a process of continuous monitoring. Hettich fittings comply with the national and international quality standards of the markets our customers operate in. The diagrams below show examples of the principles behind some of the testing processes.

#### Application

Hettich hinges can be used in living room, kitchen, bathroom and office furniture.

#### Load capacity

The quality levels indicated on products comply with the requirements of EN 15570 and satisfy the overload tests at the specified level. We will be pleased to provide any further information you may require.

#### Corrosion test

Hettich Veosys hinges satisfy the corrosion requirements under DIN EN ISO 9227-2012 in accordance with the 120 h neutral salt spray test (NSS) as well as DIN EN ISO 6270-2-2012 in accordance with the 120 h alternating condensation water climate test with alternating humidity and temperature (AHT).

#### Quality assurance

The processes for assuring the quality of Hettich hinges are certified under EN ISO 9001, Cert. No. DE8000209.

### Endurance test

The door is subjected to a specific number of opening and closing cycles.

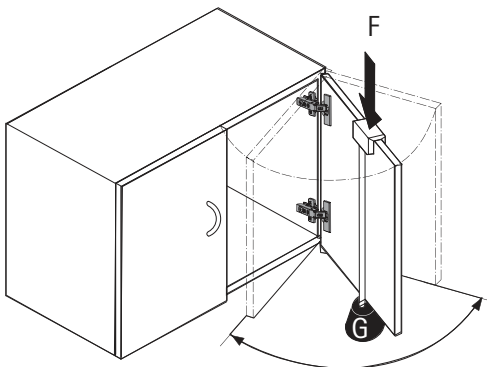

### Closing test

The door is opened by 30° and pushed closed from this position by means of a pulley and falling weight.

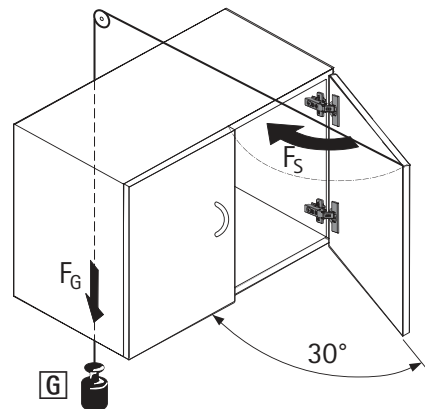

### Horizontal test

The door is over opened with a defined test force F. (This test only applies to hinges with an opening angle < 135°.)

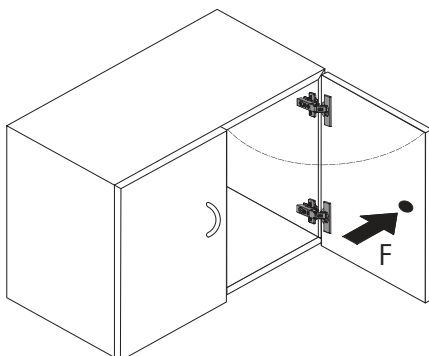

### Vertical test

The door is subjected to a specific number of opening and closing cycles under a defined additional load G.

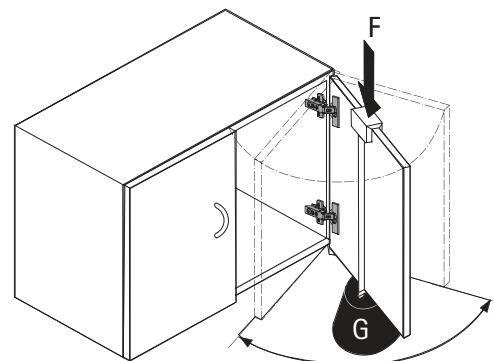

**General technical conditions**

The fitting information, screw fixing points and load capacity information contained in this document assume proper attachment using screws specified by Hettich to a chipboard panel providing a screw pull out resistance of at least 1,000 N in accordance with EN 320.

Hettich accepts no responsibility for the load capacity of furniture and its components if materials or fastening methods are used other than those stated; the furniture manufacturer must verify load capacity.

The fitting situations show in this catalogue are only intended to illustrate the possible options. The furniture manufacturer is responsible for ensuring that furniture is designed in compliance with standards, in particular with regard to meeting the requirements on safety.

We will be pleased to provide any further information you may require.

**General Terms of Sale and Delivery**

All products and services will be provided exclusively on the basis of our General Terms of Sale and Delivery published on our website at [www.hettich-agb.com](http://www.hettich-agb.com).

**Legal notice**

© Hettich Marketing- und Vertriebs GmbH & Co. KG  
32602 Vlotho, Germany

August 2022

We reserve all rights to this catalogue under copyright law. It shall not be permissible to duplicate this catalogue in any form either in whole or in part without our written consent. Subject to technical alterations. Errors and omissions excepted. Subject to colour variations.

**Hettich New Zealand**

18 Barmac Place  
East Tamaki, Auckland

Ph: 0800 438 842  
[sales-nz@hettich.com](mailto:sales-nz@hettich.com)  
[hettich.com](http://hettich.com)  
[shop.hettich.com](http://shop.hettich.com)  
[designwithhettich.co.nz](http://designwithhettich.co.nz)

